

Armstrong

Swing Gate Opener

AC Swing Motor | 120V / 230V | Original/Speedy
For Residential Use Only

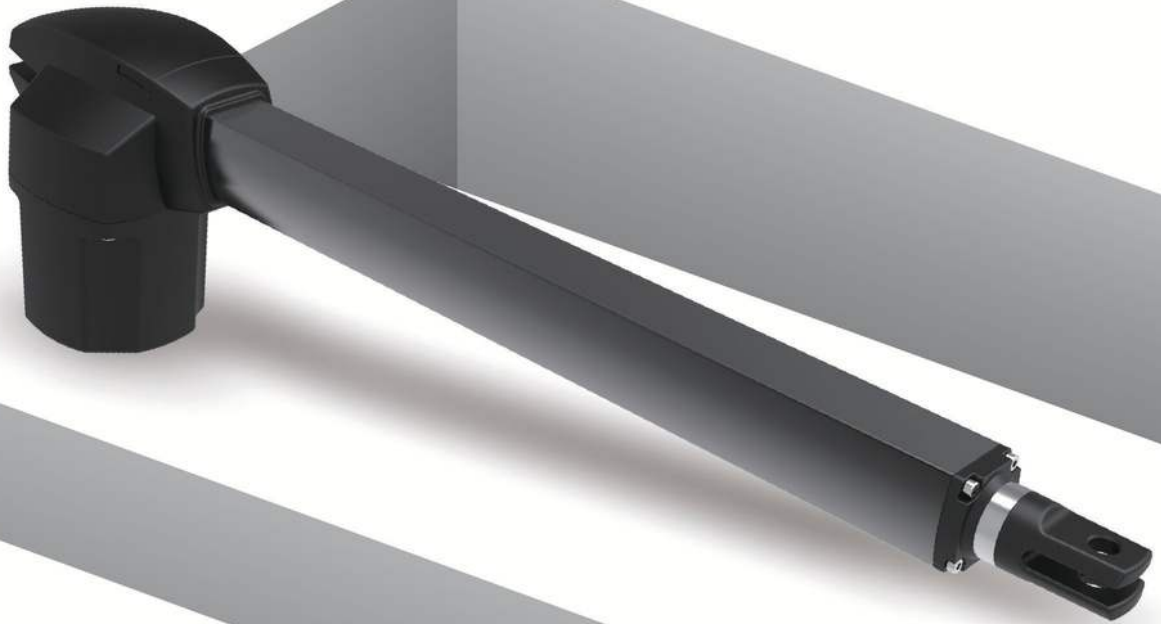

Contents

I. General Safety Warnings And Precautions	3
II. Product DescriptionAndTendeduse	4
1. Kit Content.....	4
2. ProductUsageLimits.....	5
3. Dimensions.....	5
III. Installation	6
1. Pre-InstallationChecks.....	6
2. InstallationOfTheMotors.....	7-8
IV. Commissioning	9
1. Control Board.....	9-10
2. Motor Wiring.....	11
3. Wiring Of Accessories.....	11
4. Remote Learning.....	12
5. Photocells	12
6. Safety Device Logic.....	13-14
7. Programming	15
8. Parameter Table.....	16-21
9. System Learning.....	22
V. Smartphone ControlWithCHOW!MobileApplication	23
1. WiFi/BluetoothModuleDescription.....	23
2. Apply For a NewChow!Account.....	23-24
3. Operation	25
4. Owner Shares TheDevicetoOtherUsers.....	25
5. Push Notification.....	26
6. FAQ	27-28
VI. Technical Specifications	29

I. General Safety Warnings And Precautions

WARNING!

Please read this instruction manual carefully before the installation of gate-automated system.

This manual is exclusively for qualified installation personnel.

The manufacturer is not responsible for improper installation and failure to comply with local electrical and building regulations.

Keep all the components of Armstrong system and this manual for further consultation.

In this manual, please pay extra attention to the contents marked by the symbol .

Be aware of the hazards that may exist in the procedures of installation and operation of the gate-automated system.

Besides, the installation must be carried out in conformity with local standards and regulations.

If the system is correctly installed and used following all the standards and regulations, it will ensure a high degree of safety.

Make sure that the gates works properly before installing the gate-automated system and confirm the gates are appropriate for the application.

Do not let children operate or play with the gate-automated system.

Do not cross the path of the gate-automated system when operating.

Please keep all the control devices and any other pulse generator away from children to avoid the gate-automated system being activated accidentally.

Do not make any modifications to any components except that it is mentioned in this manual.

Do not try to manually open or close the gates before you release the gear motor.

If there is a failure that cannot be solved and is not mentioned in this manual, please contact qualified installation personnel.

Do not use the gate-automated system before all the procedures and instructions have been carried out and thoroughly read.

Test the gate-automated system weekly and have qualified installation personnel to check and maintain the system at least every 6-month.

Install warning signs (if necessary) on the both sides of the gate to warn the people in the area of potential hazards.

II. Product Description And Tended use

1. Kit Content

• Motors

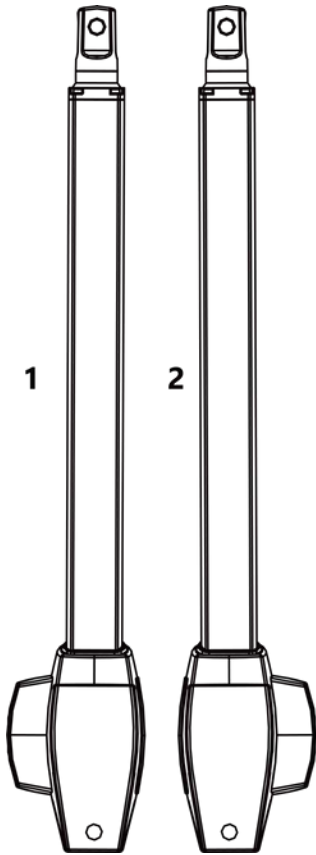

• Hardware

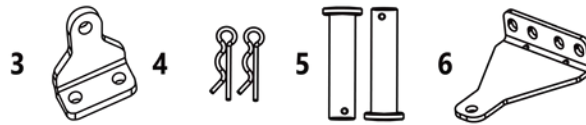

• Accessories

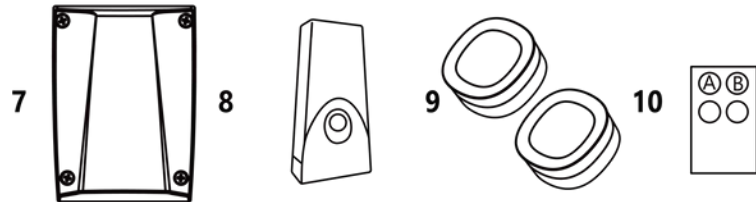

REF	DESCRIPTION	QUANTITY
1.	Motor 1 (Master)	1
2.	Motor 2 (Slave)	1
3.	Front bracket	2
4.	R-type pin	4
5.	Metal plug	4
6.	Rear bracket	2
7.	CB19 control box	1
8.	Flashing light (Optional)	1
9.	Photocells (Optional)	2
10.	Remote	2

2. Product Usage Limits

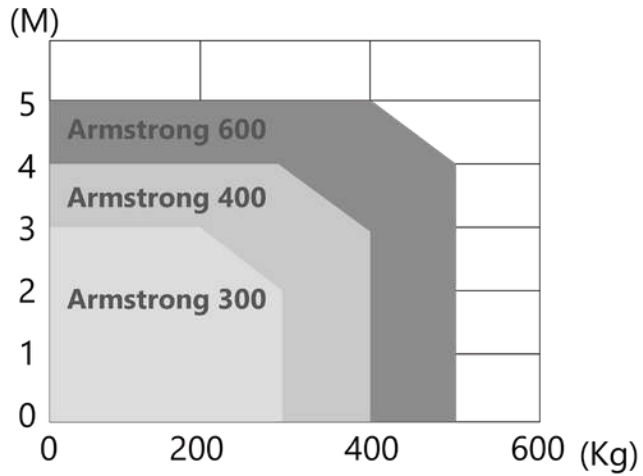

Armstrong 300
 Max gate weight : 300kg
 Max gate length : 3Meters

Armstrong 400
 Max gate weight : 400kg
 Max gate length : 4Meters

Armstrong 600
 Max gate weight : 500kg
 Max gate length : 5Meters

3. Dimensions

• Armstrong300

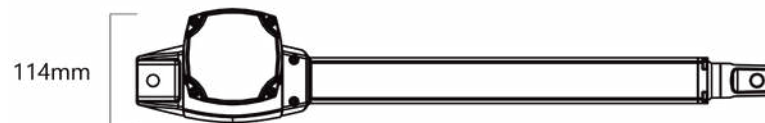
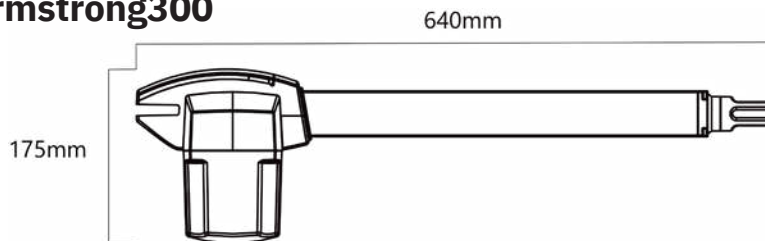

• Armstrong400

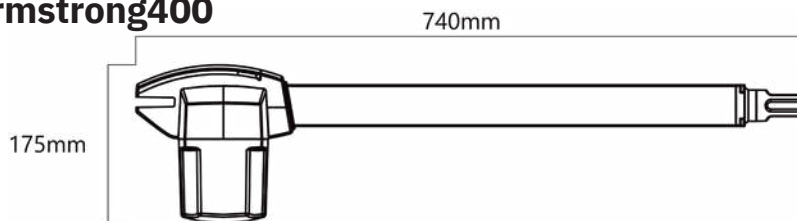

• Armstrong600

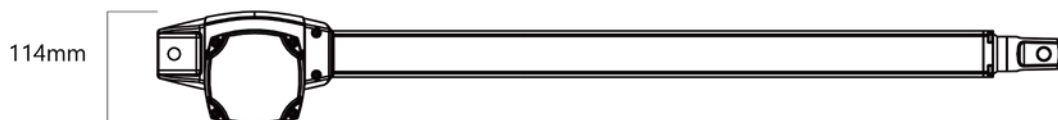
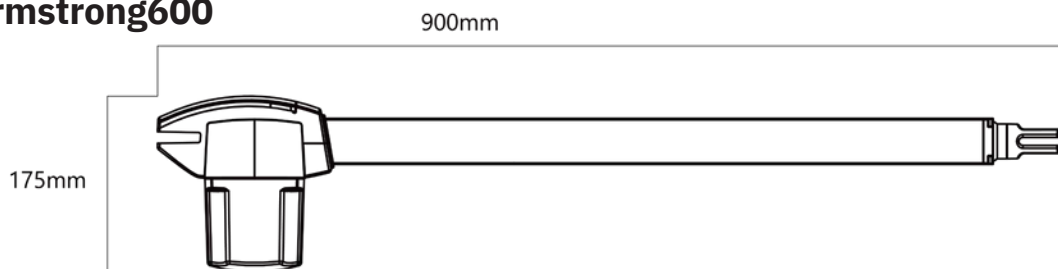

III. Installation

1. Pre-Installation Checks

Armstrong300/400/600 is not applicable to a gate which is inefficient or unsafe, neither to solve the defects due to incorrect installation nor poor maintenance.

1. Make sure the weight and dimensions of the gate conform to the operation range of Armstrong300/400/600 .
Armstrong300/400/600 if the gate specifications do not meet the requirements.
2. Make sure the gate structure conform to the criteria of automatic operation and force regulations.
3. Make sure there is no serious friction existing in the opening or closing travel of the gate leaves.
4. Make sure the gate is at horizontal level that the gate will not move aside at any position.
5. Make sure the gate can bear the impact of the motor torque when it is installed on any hole of the bracket which the surface is sufficiently sturdy.
6. Make sure the photo sensors are installed on flat surfaces to ensure the two ends of receiving and transmitting corresponded to each other.
7. Check the dimensions of the motors as below.
8. Make sure to leave enough space when the gate is opening.
9. If the gate is OPENED OUTWARD, please leave at least 70mm between the post brackets and the gate.
10. Using the leaf-opening angle as criteria to make sure all criteria .

• Open Outward

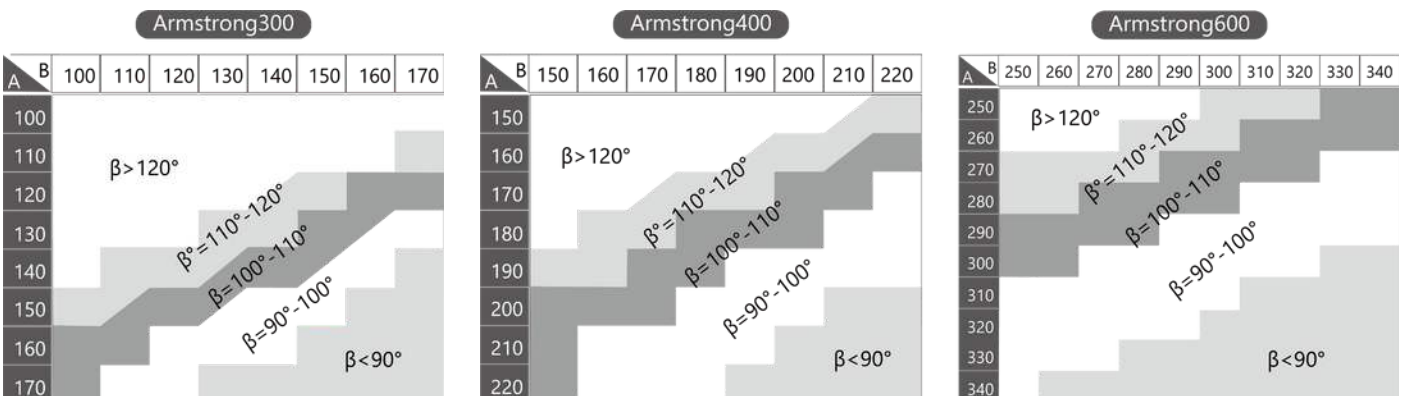
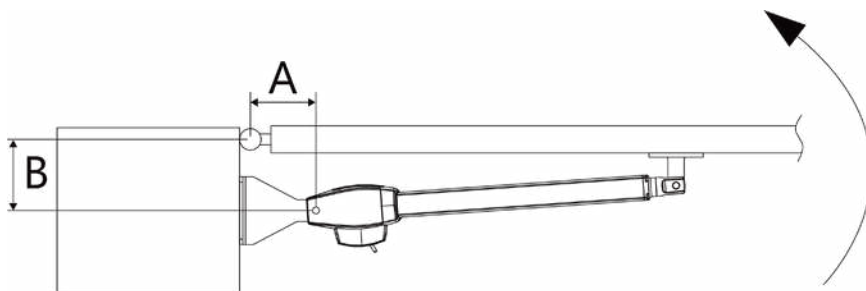

• Open Inward

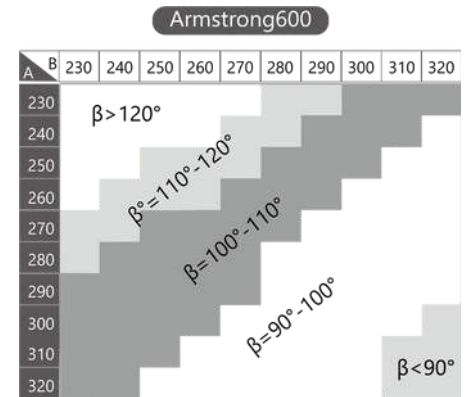
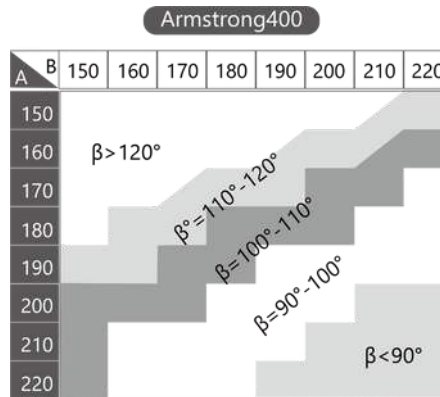
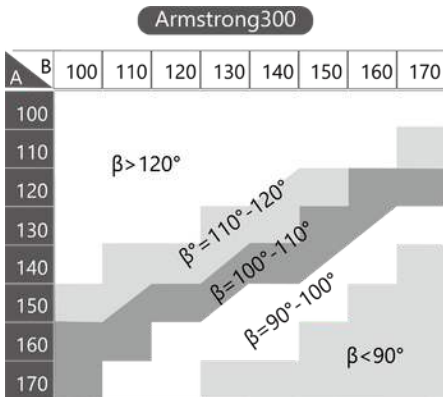
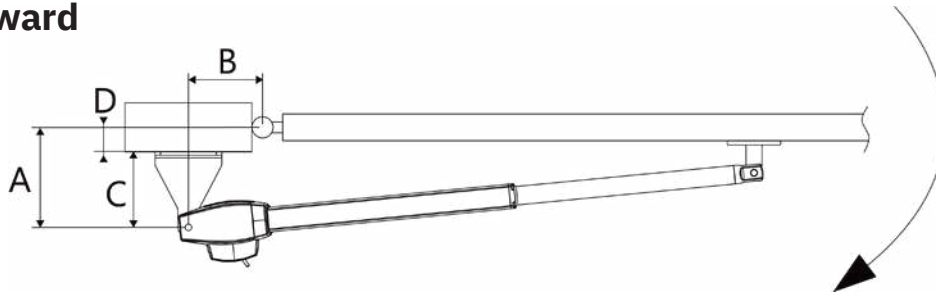

11. "C" value is 139mm.
12. "D" can be measured from the gate easily.
13. "A" = "C" + "D"
14. The value of "B" can be calculated from the value of "A" and the leaves opening angle.
Ex. If "A"=180-190mm with the leaves opening angle of 100 degrees, then the value of "B" is approximate 190mm.

****Please make sure "B" and "A" are similar or the same in value that the leaves can be operated smoothly , also to reduce the burden of the motor.****

• Release Gear

1. Remove the upper cover of the motor.
2. Turn the release axle with a hex key to release the motor.
3. The inner tube can be moved inward or outward.
4. Turn the release axle to engage the gear.

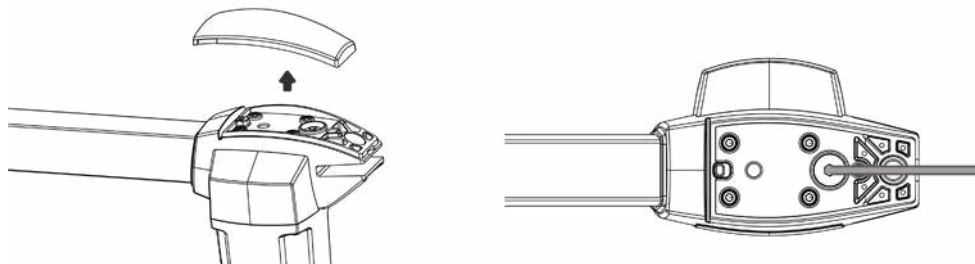

2. Installation Of The Motors

1. Choose the correct dimensions of the motors and position to be installed.
2. Check if the mounting surface the brackets to be installed is smooth, vertical and rigid..
3. Arrange the cable conduit for power supply cable of the motors.
4. Loosen the screw and remove the cover of the motor . (Figure1)
5. Place the leaves in the closed position.
6. Refer to the distance of "B" on page 6 ,place the rear plate in the correct position on the mounting surface.

7. Place 4 post brackets on the surface to be installed and mark the drilling points, then drill minimum diameter of 8mm holes by four on the mounting surface to be installed and fasten up the brackets with screws and washers. (Figure2) Make sure to leave enough space when the gate is opening.
8. Please make sure the front plate is completely installed horizontally.

• **Figure 1**

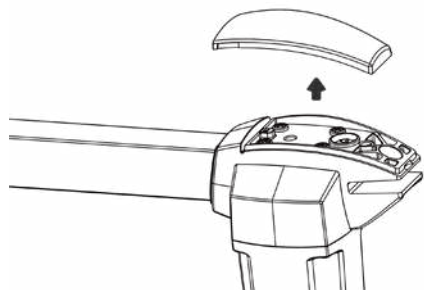

• **Figure 2**

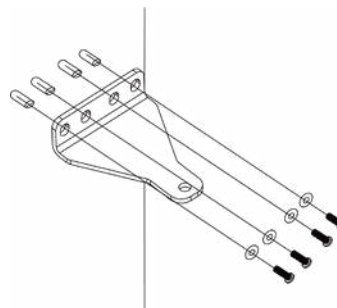

• **Figure 3**

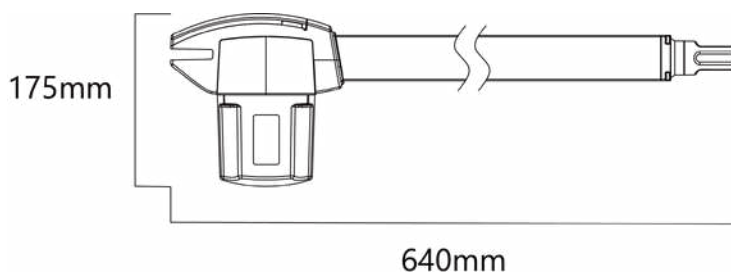

9. Clamp and fix the motor front plate on the door temporarily.
10. Lift up the motor and insert the screws into the front plate. Arrange the cable conduit for power supply cable of the motors.
11. Lift the motor overhead and push the gate to the end until the screw holes of the motor end matches the holes on the rear plate. Fasten the motor to the rear plate with the bolt. (Figure4)
12. Fasten the nut tightly and loosen it for half round for motor supporting in rotating.
13. Fasten the motor front end to the front plate with the plug ① and ② pin tightly .
14. Use appropriate release key to release the gear motor.
15. Try to push the released gate and make sure the motor can be manually moved easily.
16. Make sure the motor front plate can be fastened on the gate to be installed permanently.
17. Use the appropriate release key to fasten the gear motor again.
18. Loosen the plastic nut under the power cable of the motor end, and penetrate the power cable through the nut and screw it up.

• **Figure 4**

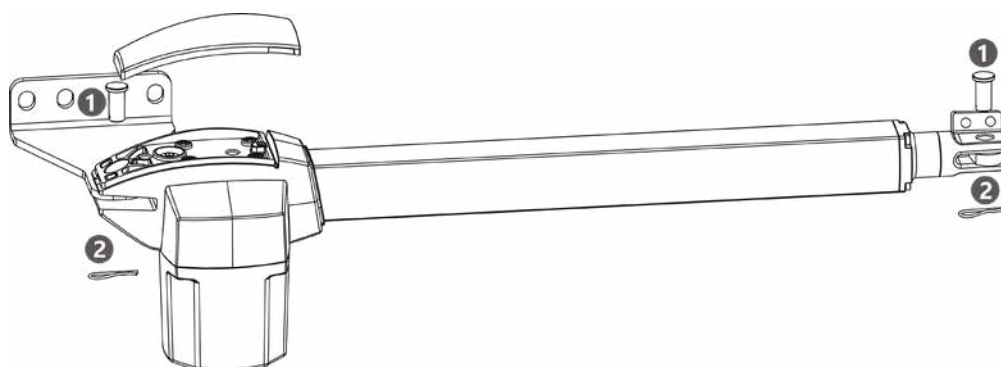

- **Electrical Connection Specifications**

Terminal	230V System	120V System
230V	Max250V/Max2A	Max140V/Max4A
LAMP		
M1-F/M1-R/COM		
M2-F/M2-R/COM		
24VAC	Max30V_AC/Max2A	
LAT+/-	Max15V AC//Max3A	
5V	Max5V/Max50mA	
S1/S2	Max5V/Max0.5mA	
LMT 1/2		
LMT 3/4		
STOP	Max5V/Max1mA	
SE		
DKEY		
SKEY		
PH1	Max12V/Max1.2mA	
PHVCC	Max14V/Max0.5A	
PH2	Max12V/Max1.2mA	
PHVCC	Max14V/Max0.5A	

2. Motor Wiring •

Time Mode

Refer to parameter
Table-parameter A1-1.

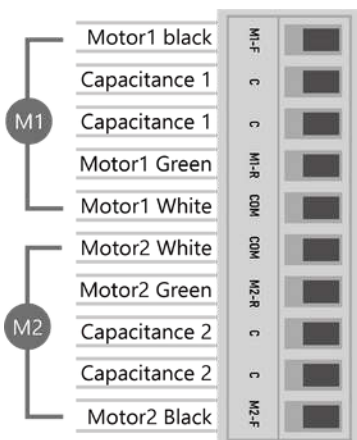

• Limit Switch Mode

Refer to parameter
Table-parameter A1-0.

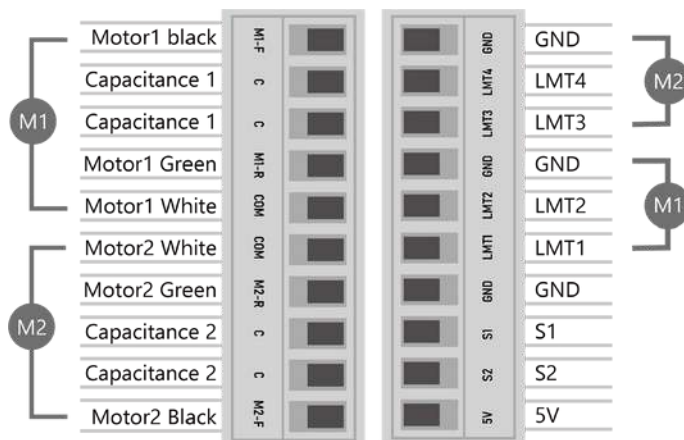

3. Wiring Of Accessories

• Safety Device 1 Wiring

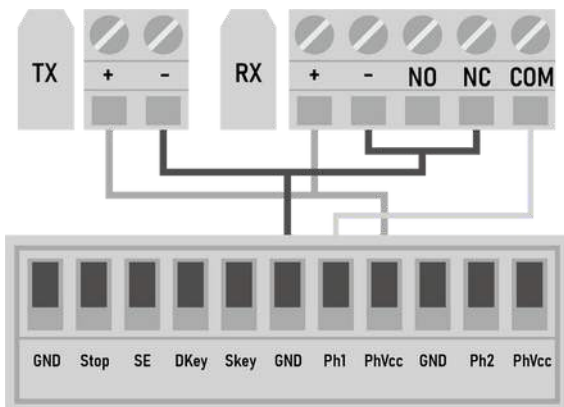

• Safety Device 2 Wiring

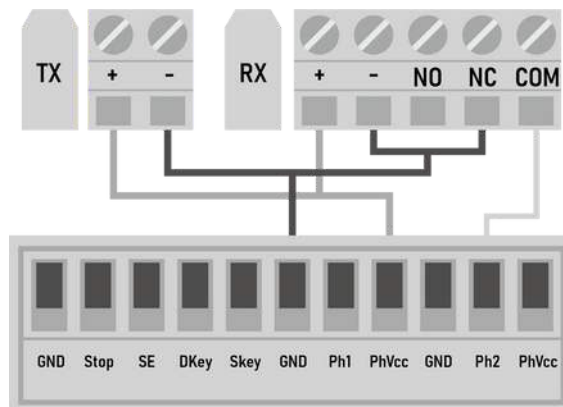

• Auxiliary Device Wiring

Dkey : Complete Open
Skey : Partial Open

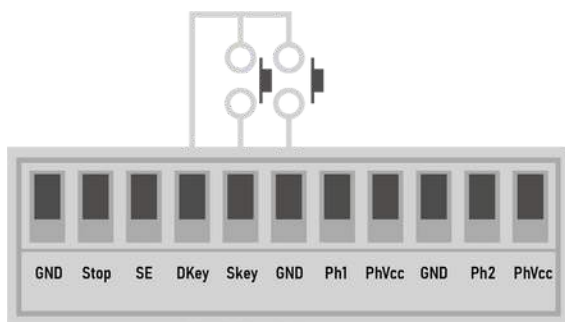

• 12V Available To Power Accessories

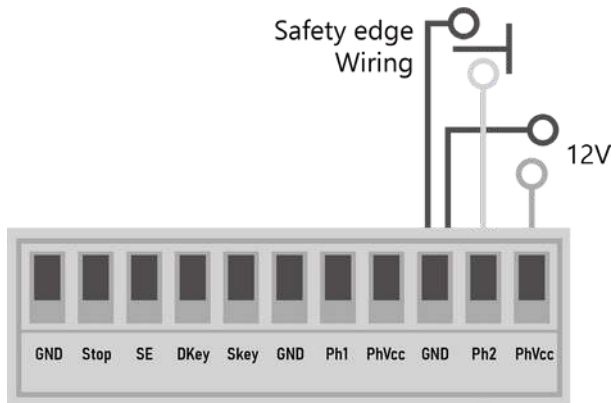

4. Remote Learning

• Pairing Remotes

Press the RF button for 2 seconds and the LED display show **RFL**
press any key of the remote control within 10 seconds,
the LED will show remote control code, and flash slowly 3 times.

• Delete Single Remote(By Pressing Remote Button)

Press the RF button twice and the LED shows **DKY**
Press any key of the paired remote and the LED show remote control code and blinks for 3 times .
Wait the code goes OFF .

• Delete Single Remote(By Pressing SW4 <SET>On Control Board)

press RF button 3 times and LED show the remote control code , press SW3 ▲ / SW5 ▼ to
select the code you want delete and pressing SW4(SET),
the code Flash slowly 3 times to finish deleting the remote control.

• Delete All Remote

Press the RF button for 5 seconds and the LED shows
Press any key of paired remote and LED shows blinks **DAL** times , the control panels
deletes all the paired remotes.

• Pairing Remotes With a Paired Remote

Press a new remote for 5 seconds and the Flashing light will be **ON**.
Press the paired remote for 3 times and the Flashing light will blink.
Press any key of a new remote to pair.

5. Photocells

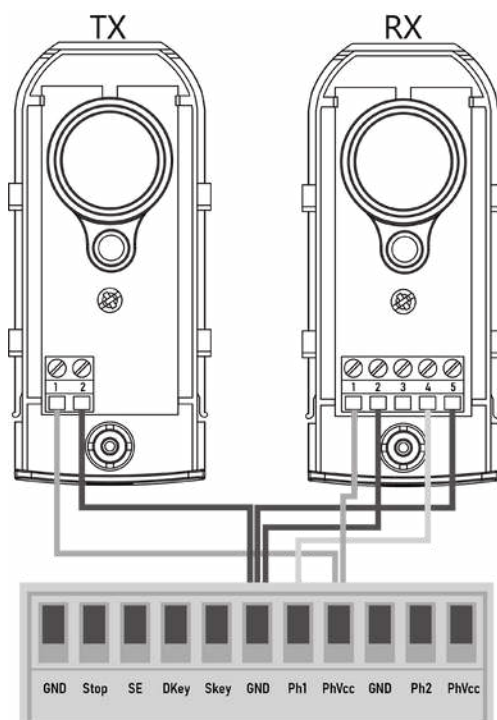

Open the cover and connect wires .
Mounted the receiver and transmitter on the
proper position.
Ensure there are no obstacles between receiver
and transmitter.
For optimal efficiency, the receiver and
transmitter should be properly aligned.
Power-up the photocells and make sure the
LED light on receiver and transmitter are ON.

6. Safety Device Logic

• F5 PH1 functions

Parameter	Function	Gate Status	Reaction
F5-0 (Default setting)	PH1 function OFF	No function	No function
F5-1	Photocell-Close	Gate fully close	Not allow to open
		Gate fully open	Fast closing
		Stop during cycle	Not allow to Open/Close
		Closing phase	Open
		Opening phase	No effect
F5-2	Photocell-Open	Gate fully close	Not allow to open
		Gate fully open	Not allow to close
		Stop during cycle	Not allow to Open/Close
		Closing phase	No effect
		Opening phase	Close
F5-3	Safety edge	Gate fully close	Not allow to open
		Gate fully open	Reload auto-closing time
		Stop during cycle	Not allow to Open/close
		Closing phase	Open for 2 seconds
		Opening phase	Close for 2 seconds

- **F6 PH2 functions**

Parameter	Function	Gate Status	Reaction
F6-0 (Default setting)	PH2 function OFF	No function	No function
F6-1	Photocell-Close	Gate fully close	Not allow to open
		Gate fully open	Fast closing
		Stop during cycle	Not allow to Open/Close
		Closing phase	Open
		Opening phase	No effect
F6-2	Photocell-Open	Gate fully close	Not allow to open
		Gate fully open	Not allow to close
		Stop during cycle	Not allow to Open/Close
		Closing phase	No effect
		Opening phase	Close
F6-3	Safety edge	Gate fully close	Not allow to open
		Gate fully open	Reload auto-closing time
		Stop during cycle	Not allow to Open/close
		Closing phase	Open for 2 seconds
		Opening phase	Close for 2 seconds

7. Programming

• Indication On The LED Display

 = System learning not been done yet

 = Double gate

 = Single gate

 = Remote learning

 = Delete single remote

 = Delete all remotes

 = Open

 = Close

 = Stop

 = Motor into the system learning mode, do not interrupt during this procedure.

 = the panel did not detected the M1+/M1 and M2+/M2 both been connected before the system learning procedure, check for 2 motors' wire connection, for dual gate system.

LED Display

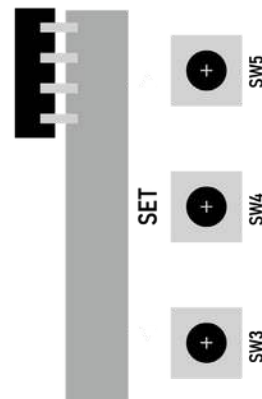
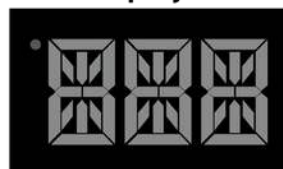

Indication example on the LED display

• Parameter Settings

Press and hold ▲ / **SET** for 3 seconds

The LED display « A1 » parameter setting

Select main setting with ▲ / ▼ then confirm with SET

Display of the sub-setting (ex: parameter A1-subvalue=1)

Modify sub-setting value ▲ / ▼

Validate sub-setting value with **SET**

Press ▲ / ▼ to display and configure other settings

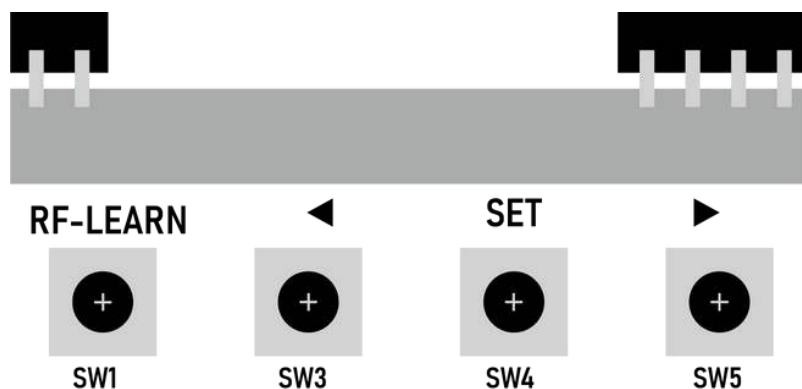

8. Parameter Table

Setting	Function	Parameters	Description
A1	Limit mode	A1-0	Limit switch mode
		A1-1	Time mode (default setting)
A2	Operation mode	A2-0	Standard mode (default setting)
		A2-1	Condominium mode
		A2-2	Holiday mode
A3	Double/Single gate	A3-0	Single gate
		A3-1	Double gate (default setting)
A4	LED direction	A4-0	Control box (default setting)
		A4-1	Arm gate opener
A5	Operation direction	A5-0	Open inward (default setting)
		A5-1	Open outward
C1/C2	C1 Slowdown area for opening C2 Slowdown area for closing	C1/C2-0	No slowdown area
		C1/C2-1	5% slowdown area
		C1/C2-2	10% slowdown area
		C1/C2-3	15% slowdown area
		C1/C2-4	20% slowdown area (default setting)
		C1/C2-5	25% slowdown area
		C1/C2-6	30% slowdown area
C3/C4	C3 Delay time for opening C4 Delay time for closing	C3/C4-0	No delay
		C3/C4-1	1 seconds
		C3/C4-2	2 seconds (C3 default setting)
		C3/C4-3	3 seconds (C4 default setting)
		C3/C4-4	4 seconds
		C3/C4-5	5 seconds
		C3/C4-6	6 seconds
		C3/C4-7	10 seconds
		C3/C4-8	15 seconds
C3/C4-9	20 seconds		
C5/C6	C5 Motor1 running time for opening C6 Motor2 running time for opening	0-90 seconds	Default setting 22 seconds
	C7 Motor1 running time for closing C8 Motor2 running time for closing	0-90 seconds	Default setting 24 seconds
E1/E2	E1 over-current reaction while opening E2 over-current reaction while closing	E1/E2-	Stop (E1 default setting)
		0	Reverse for 1 second
		E1/E2-1	Reverse for 2 seconds (E2 default setting)
		E1/E2-	Reverse for 3 seconds
		2	Reverse for 4 seconds
		2	Reverse till the end

E1/E2-

3

E1/E2-

4

E1/E2-

5



TMT

AUTOMATION INC.

Setting	Function	Parameters	Description
E3	Reverse Time when reach the close limit	E3-0	(default setting)
		E3-1	0.1 second
		E3-2	0.2 second
		E3-3	0.3 second
		E3-4	0.4 second
		E3-5	0.5 second
		E3-6	0.6 second
E4	Ignore over-current time when start	E4-0	Function OFF
		E4-1	1 second
		E4-2	2 seconds
E5	Over-current sensitivity	E5-0	20%
		E5-1	30%
		E5-2	40%
		E5-3	50%
		E5-4	60%
		E5-5	70%
		E5-6	80% (default setting)
		E5-7	90%
		E5-8	100%
E6	Force	E6-0	20%
		E6-1	30%
		E6-2	40%
		E6-3	50%
		E6-4	60%
		E6-5	70%
		E6-6	80% (default setting)
		E6-7	90%
		E6-8	100%
F1	Auto-closing time	F1-0	No Auto-closing (default setting)
		F1-1	3 seconds
		F1-2	10 seconds
		F1-3	20 seconds
		F1-4	40 seconds
		F1-5	60 seconds
		F1-6	120 seconds
		F1-7	180 seconds
		F1-8	300 seconds
F2	Fast closing (Follow Me)	F2-0	0 seconds
		F2-1	1 seconds
		F2-2	2 seconds
		F2-3	3 seconds
		F2-4	4 seconds (default setting)
		F2-5	6 seconds
		F2-6	8 seconds
		F2-7	10 seconds

Setting	Function	Parameters	Description
F3	Pedestrian mode	F3-0	10%
		F3-1	20%
		F3-2	30%
		F3-3	40%
		F3-4	50%
		F3-5	60%
		F3-6	70%
		F3-7	80%
		F3-8	90%
F4	Flashing light – Pre flashing	F4-0	0 second (default setting)
		F4-1	1 second
		F4-2	2 second
		F4-3	3 second
		F4-4	4 second
		F4-5	6 second
		F4-6	8 second
		F4-7	10 second
F5	Ph1 Photocells mode	Please refer to Safety device logic	
F6	Ph2 Photocells mode	Please refer to Safety device logic	
F7	Buzzer	F7-0	OFF (default setting)
		F7-1	ON
F8	Latch release mode	F8-0	Function OFF (default setting)
		F8-1	Stander gate opening
		F8-2	Releasegatetensionbefore opening(Gatereversingfor 1s)
F9	Courtesy light	F9-0	OFF (default setting)
		F9-1	5 seconds
		F9-2	10 seconds
		F9-3	20 seconds
		F9-4	30 seconds
		F9-5	40 seconds
		F9-6	60 seconds
		F9-7	80 seconds
		F9-8	100 seconds
		F9-9	120 seconds
H1	A Button	H1-0	Function OFF
		H1-1	StepbystepOpen/Stop/Close/Stop (default setting)
		H1-2	Open/Stop/Close
		H1-3	Ped mode
		H1-4	Open
		H1-5	Stop
		H1-6	Close
		H1-7	Lamp
		H1-8	Auto-closing switch
		H1-9	Holidaymode switch

Setting	Function	Parameters	Description
H2	B Button	H2-0	Function OFF (default setting)
		H2-1	Step by step Open/Stop/Close/Stop
		H2-2	Open/Stop/Close
		H2-3	Ped mode
		H2-4	Open
		H2-5	Stop
		H2-6	Close
		H2-7	Lamp
		H2-8	Auto-closing switch
		H2-9	Holiday mode switch
H3	C Button	H3-0	Function OFF (default setting)
		H3-1	Step by step Open/Stop/Close/Stop
		H3-2	Open/Stop/Close
		H3-3	Ped mode
		H3-4	Open
		H3-5	Stop
		H3-6	Close
		H3-7	Lamp
		H3-8	Auto-closing switch
		H3-9	Holiday mode switch
H4	D Button	H4-0	Function OFF (default setting)
		H4-1	Step by step Open/Stop/Close/Stop
		H4-2	Open/Stop/Close
		H4-3	Ped mode
		H4-4	Open
		H4-5	Stop
		H4-6	Close
		H4-7	Lamp
		H4-8	Auto-closing switch
		H4-9	Holiday mode switch
J1	Skey terminal	J1-0	Function OFF
		J1-1	Double gate Open/Stop/Close/Stop
		J1-2	Single gate Open/Stop/Close/Stop (default setting)
		J1-3	Ped mode
		J1-4	Open
		J1-5	Stop(NO)
		J1-6	Stop(NC)
		J1-7	Close
		J1-8	Lamp
		J1-9	Auto-closing switch
		J1-10	Holiday mode switch

Setting	Function	Parameters	Description
J2	Dkey terminal	J2-0	Function OFF
		J2-1	Double gate Open/Stop/Close/Stop (default setting)
		J2-2	Single gate Open/Stop/Close/Stop
		J2-3	Ped mode
		J2-4	Open
		J2-5	Stop(NO)
		J2-6	Stop(NC)
		J2-7	Close
		J2-8	Lamp
		J2-9	Auto-closing switch
		J2-10	Holiday mode switch
J3	Stop terminal	J3-0	Function OFF
		J3-1	Double gate Open/Stop/Close/Stop
		J3-2	Single gate Open/Stop/Close/Stop
		J3-3	Ped mode
		J3-4	Open
		J3-5	Stop(NO) (default setting)
		J3-6	Stop(NC)
		J3-7	Close
		J3-8	Lamp
		J3-9	Auto-closing switch
		J3-10	Holiday mode switch
J4	SE terminal	J4-0	Function OFF (default setting)
		J4-1	Movement is stopped , if the SafetyEdge is triggered during closing
		J4-2	Movement is reversed for 2 sec , if the Safety Edge is triggered during closing
		J4-3	Movement is reversed to the end, if the SafetyEdge is triggered during closing
U1	Return to the default setting (Keep remote pairing& system learning memory)	U1	The parameters return to the default setting
U2	Return to the default setting (Delete all memory)	U2	The parameters return to the default setting Delete all the remote pairing Delete all the system learning memory

Condominium Mode				
Trigger Device \ Status of Gate	Step by step button	Ped button	PH2	PH1
Stop in the middle	Open till fully open and reload auto-closing time	No effect. Auto-closing countdown	When Ph2 is triggered, auto-closing stops until the obstacle is removed.	When Ph1 is triggered, auto-closing stops until the obstacle is removed.
Gate fully open	Reload auto-closing time	No effect. Auto-closing countdown	When Ph2 is triggered, auto-closing stops until the obstacle is removed.	When Ph1 is triggered, auto-closing stops until the obstacle is removed.
Opening phase	No effect	No effect	No effect	No effect
Gate fully close	Open the gate until it's fully open and start auto-closing countdown	No effect	No effect	No effect
Closing phase	Open the gate until it's fully open and start auto-closing countdown	No effect	When Ph2 is triggered, reverse to the fully open position. Auto-closing stops until the obstacle is removed.	When Ph1 is triggered, reverse to the fully open position, Auto-closing stops until the obstacle is removed.

9. Operation time adjusting

💡 The default setting is A1-1 which is time mode. With the time mode, the system doesn't have to run system learning. The motors operates as set operation time as parameter C5/C6/C7/C8

- **C5/C6 control the operation time for opening. Please adjust to find a suitable value for your gate.**

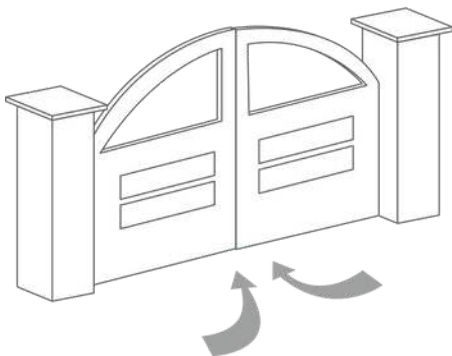

- **C5**
C5 motor 1 running time for opening
0-90 seconds
Default setting 22 seconds
- **C6**
C6 motor 2 running time for opening
0-90 seconds
Default setting 22 seconds

- **C7/C8 control the operation time for closing. Please adjust to find a suitable value for your gate.**

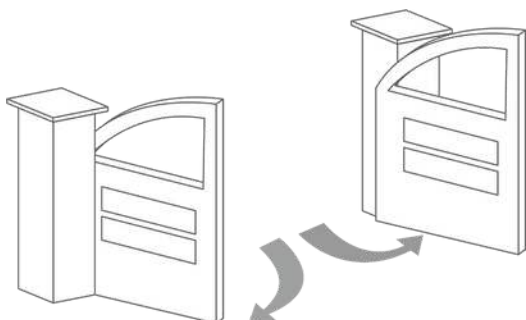

- **C7**
C7 motor 1 running time for opening
0-90 seconds
Default setting 24 seconds
- **C8**
C8 motor 2 running time for opening
0-90 seconds
Default setting 24 seconds

V. Smartphone Control With CHOW! Mobile Application

1. WiFi/Bluetooth Module Description

• Chow_Smart phone controlled gate opener

Chow is a system connecting gate opener to smart phones, allowing you to operate your gate automation by smart phones. Chow allows multiple users to operate the gate openers anywhere any time. Camera is recommended to be installed with Chow to have a view during your operation.

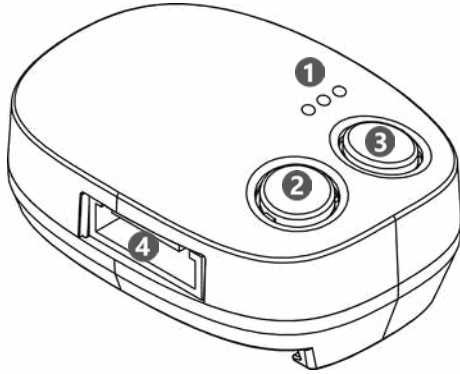

- 1 LED Display
- 2 R Button (press to restart)
- 3 P Button
- 4 Terminals

Before starting pairing

1. Press the (P) button for 5 seconds and release it.
2. Press the (R) button once to reboot theWiFi/bluetooth module.

• LED Indications And Buttons

Return to the factory setting:

Press the (P) button for 5 seconds and press the (R) button.

The Blue LED starts to blink. The smart control box has returned to the factory setting.

BLUE LED : Blue LED is a indicator for the Bluetooth connection.

GREEN LED : Green LED is a indicator for the WiFi connection.

RED LED : Red LED blinks indicates wrong operations or system errors.

Please refer to FAQ when the Res LED is ON.

2. Apply For a New Chow! Account

1. Please scan the QR code and download the Chow! App
2. Press sign up icon and press the agree icon to continue
3. Please type the following information for registration:

- a. Email(enter twice for verification)
- b. Password(enter twice for verification)
- c. The password should have at least 1 English character and at least 8 characters in total



4. The system will send a link to your email when the registration succeeded.
5. Please go to your email, and click the link to activate your Chow! account.
6. Please log in your Chow! account.

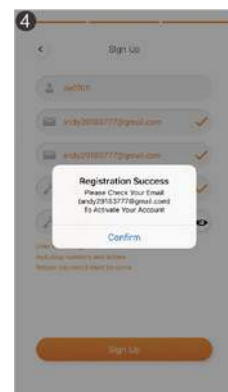
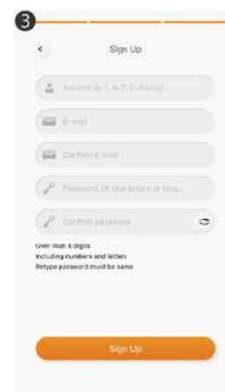
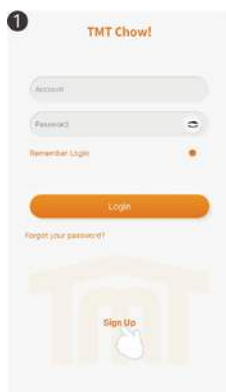

• Connect the Wifi/Bluetooth Module to the Chow! App

1. ****Please turn ON the Bluetooth function of your smartphone****
2. Tap the (+) icon to add new device.
3. Tap the type of your device to add a new device.
4. Please check if the product has the WBT sticker.

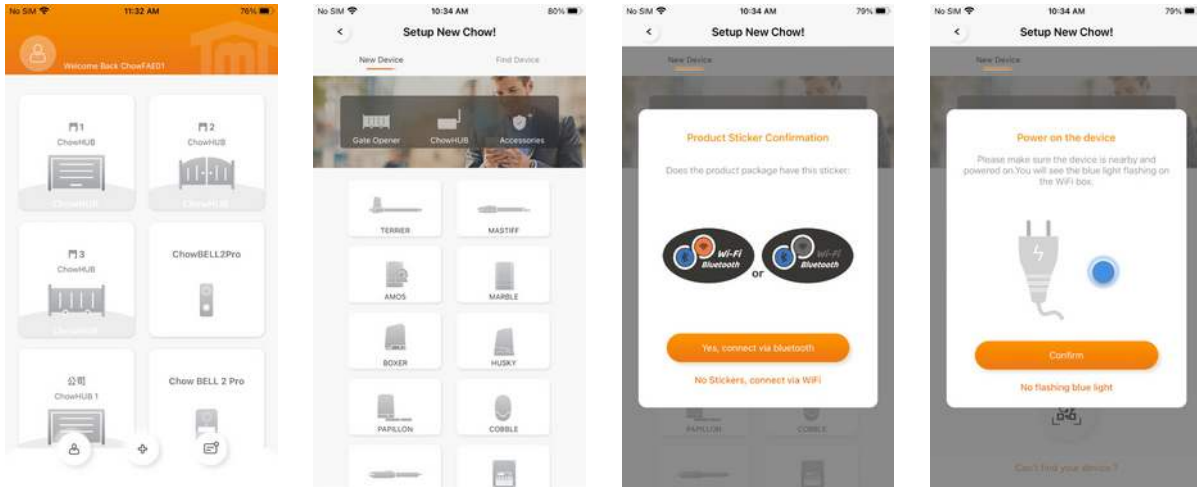

5. Please check if you power the device.
6. Please select your device or scan QRcode on device.
7. Set a security PIN code by enter the same code twice.
8. Entering the correct password of your Wi-Fi.
9. After connection countdown, you can name your device.

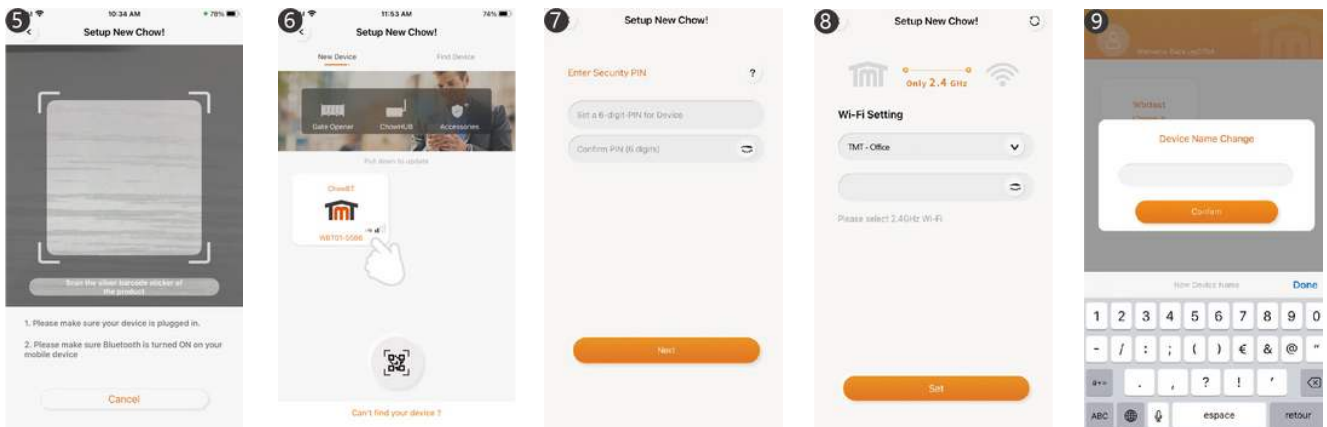

3. Operation

1. Tap the device on your main page.
2. Tap the Open/Stop/Close to control gate opener.
3. Tap the Bluetooth icon to switch to Bluetooth control mode

****Please turn ON the Bluetooth function of your smartphone****

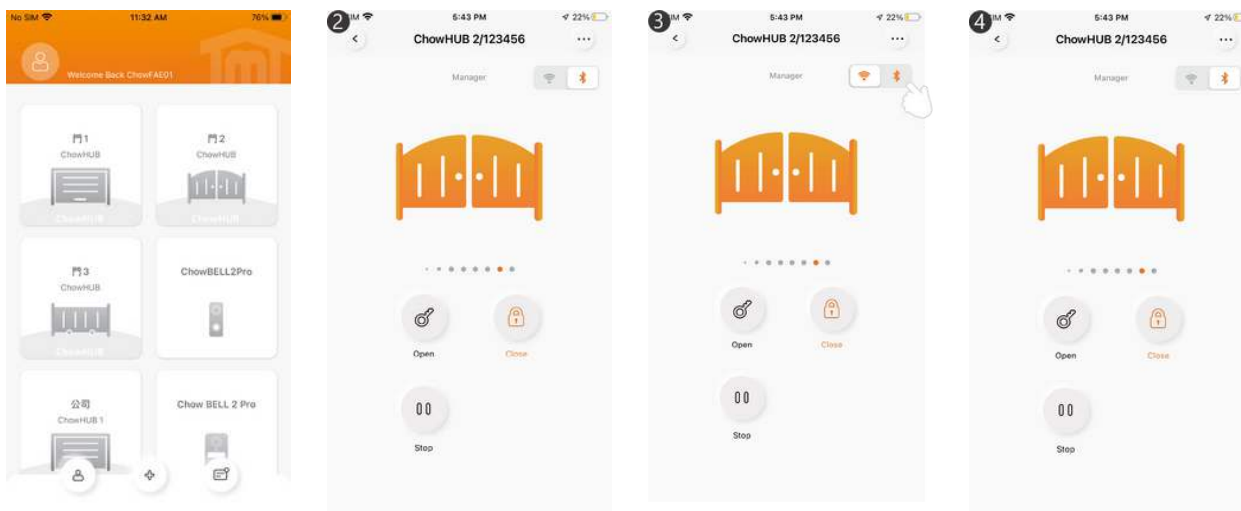

Note: Only one user can access the Bluetooth control mode. Once the first user leaves this operation page, the second user can access this device.

4. Owner Shares The Device to Other Users

1. Press the icon on the corner to enter the account management page.
2. Tap the manage shared device.
3. Enter the account which you are going to share.
4. Choose the device you are going to share and tap next.

- a. The Owner can decide the permission of device sharing. A manager can share and operate this device, but a normal user can only operate it.
- b. One device can only be shared to 10 users.

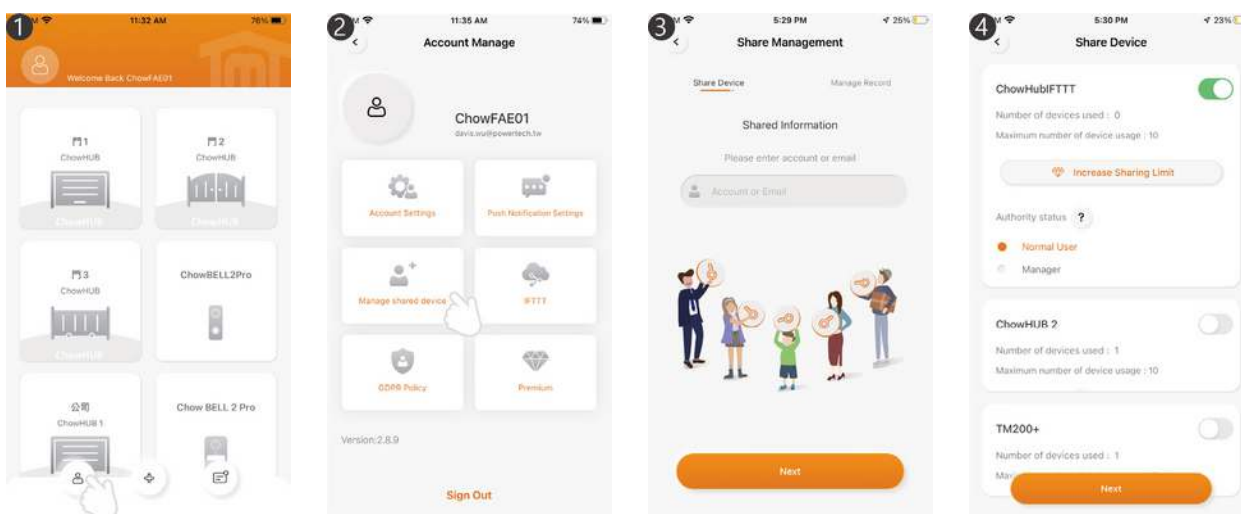

5. Push Notification

Press the icon on the corner to enter the account management page.
Tap the push notification setting.
Turn ON the switches of the notification.

****Please go to the settings page of your smartphone,
find TMT Chow! and allow the notifications****

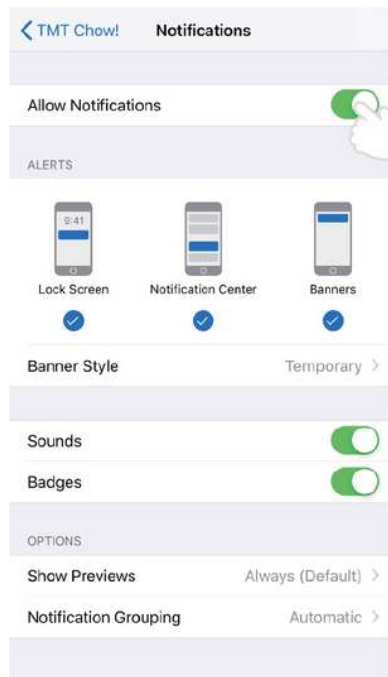
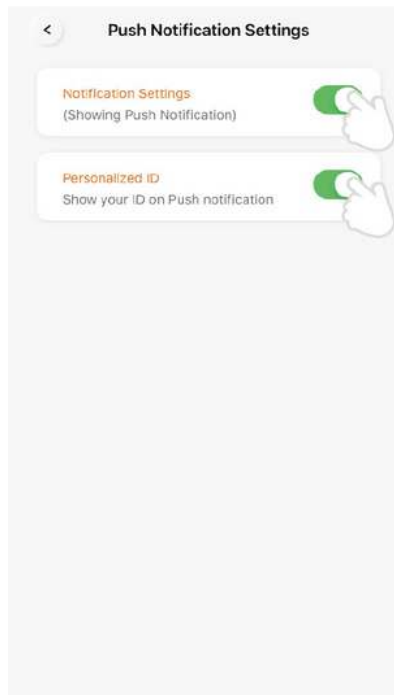
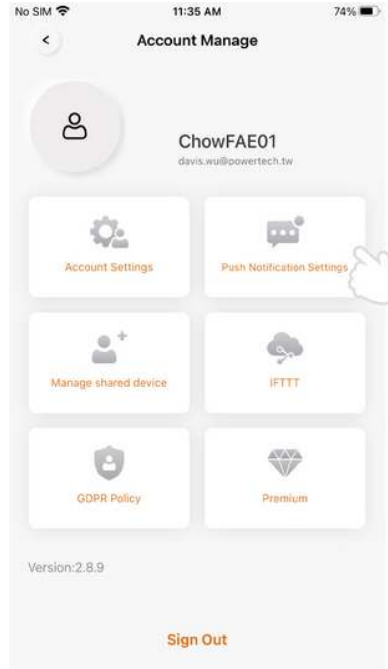

6. FAQ

- **Question 1** The Blue LED is NOT Blinking when pairing.
- **Answer 1** Press(P) button of the Wifi box.

- **Question 2** Blue and Green LED blinks alternatively when Connecting to Chow by the first user.
- **Answer 2** Entering a wrong password to your Wifi network.

- **Question 3** RED blink when Connecting to Chow by the first user.
- **Answer 3** The Wifi box cannot get a IP from the router. Please disconnect other device.

- **Question 4** RED blink when Enter the PIN code.
- **Answer 4** Entering the wrong PIN code. Please check with the first user.

- **Question 5** Green LED is blinking.
- **Answer 5** Wifi signal is weak. Please adjust the antenna of the Wifi box.

- **Question 6** Red LED ON.
- **Answer 6** Red LED ON indicates a system error. Please return to the factory setting as mentioned below.

- **Question 7** Return to the factory setting.
- **Answer 7** Return to the factory setting is used when you lose your PIN code for sharing the device. After return to the factory setting, please follow the previous indications to reconnect the Chow.

1. Tap the device icon on the main page for 3 seconds and delete the device
2. Open the Wifi box, press the (P) button for 5 seconds and release it.
3. Plug out the and reconnect the write to restart the Wifi box.
4. Do the (C1. Connecting to Chow by the first user) to get a new PIN code.



- **Question 8** How should I change my PIN code.
- **Answer 8** Enter the operation page of the device in Chow » Chick the (Device Information)in the setting page » Tap(PIN Code Setting)

VI. Technical Specifications

Model Name	Armstrong300	Armstrong400	Armstrong400
Max gate length	3 meters	4 meters	5 meters
Max gate weight	300 kilos	400 kilos	500 kilos
Voltage	230V / 120V	230V / 120V	230V / 120V
Motor Speed (RPM)	1450/1750	1450/1750	1450/1750
Stroke Length (mm)	300	400	600
Duty cycle	50%	50%	50%
No-load Speed (mm/s)	16	16	16
No-load Current	≤1A / ≤1.5A	≤1A / ≤1.5A	≤1A / ≤1.5A
Rated Current	≤2A / ≤3A	≤2A / ≤3A	≤2A / ≤3A
Noise	≤55db	≤55db	≤55db
Operating Temperature	-20°C+50°C	-20°C+50°C	-20°C+50°C
Waterproof	IP44	IP44	IP44



 +212666-453-856

 +212522-502-539