

HUSKY SERIES

SLIDING GATE OPENERS

230V AC MOTOR
FOR RESIDENTIAL
USER MANUAL

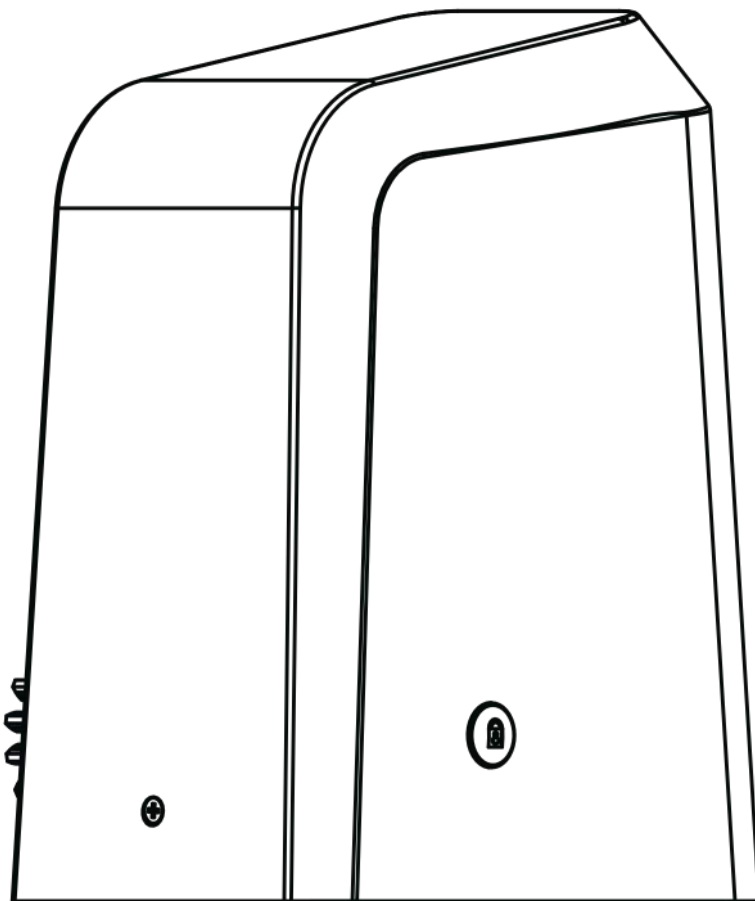

Reuse
Reduce
Recycle



INDEX

1.General Precaution: 2). Installation:	2
2.1 Standard Installation Demonstration	3
2.2 Description Of Device	3
2.3 Dimension Of Device	3
2.4 Installation Of Motor Gear And Gear Rack	4
2.5 Checking For Installation	4
2.6 Emergency Release	5
2.7 Control Board	5
3). Setting of Control Board	6
3.1 Sw1 Dip Switch Setting – Power Supply	7
	7
3.2 Sw2_1 Photocells Activation (Refer To 7.Photocell Installation Guide)	7
3.3 Sw2_2 Safety Device Function Mode	7
3.4 Sw2_3, Sw2_4 Auto-closing	7
3.5 Sw2_5 Remote Mode	7
3.6 Sw2_6 Wi-fi Mode (Refer to Wifi Box User Manual)	7
3.7 Sw2_7 Alarm Buzzer	7
3.8 Sw2_8 Operation Direction	7
3.9 Vr Adjustable Vr Knobs	8
4). Transmitter Setting And System Learning	8
4.1 Transmitter Setting	8
4.2 System Learning	8
4.3 Transmitter Copy	8
4.4 Gate Operating	8
5). Other Function	9
5.1 Led Indications	9
5.2 Deceleration Function	9
5.3 Gate-moving Logic	9
5.4 Wires Connecting For Two Gates / Operating	9
6).Technical Characteristics:	9
6.1 Technical Data Sheet Of Husky Series	9
6.2 Transmitter Data Sheet	9
7).Photocell Installation Guide	10

1.GENERAL PRECAUTION:

WARNING :

This user manual is only for qualified technicians who is specialized in installations and automations.

- (1)All installations, electrical connections, adjustments and testing must be performed only after reading and understanding of all instructions carefully.
- (2)Before carrying out any installation or maintenance operation, disconnect the electrical power supply by turning off the magneto thermic switch connected upstream and apply the hazard area notice required by applicable regulations
- (3)Make sure the existing structure is up to standard in terms of strength and stability
- (4)When necessary, connect the motorized gate to reliable earth system during electricity connection phase.
- (5)Installation requires qualified personnel with mechanical and electrical skills.
- (6)Keep the automatic controls (remote, push bottom, key selectors...etc) being placed properly and away from children.
- (7)For replace or repair of the motorized system, only original parts must be applied. Any damage caused by inadequate parts and methods will not be claimed to motor manufacturer.
- (8)Never operate the drive if you have any suspect with what it might be faulty or damage to the system.
- (9)The motors are exclusively designed for the gate opening and closing application, any other usage is deemed inappropriate. The manufacture should not be liable for any damage resulting from the improper use. Improper usage should void all warranty, and the user accepts sole responsibility for any risks there by may accrue.
- (10)The system may only be operated in proper working order. Always follow the standard procedures by following the instructions in this installation and operating manual.
- (11)Only command the remote when you have a full view of the gate.

TMT AUTOMATION INC. shall not be liable for any injury, damage, or any claim to any person or property which may result from improper use or installation of this system.

Please keep this installation manual for future reference.

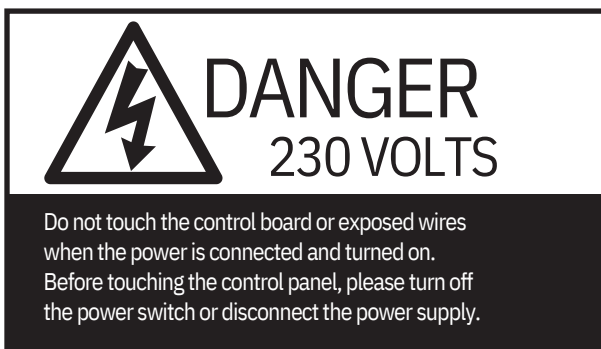

2). INSTALLATION:

2.1 STANDARD INSTALLATION DEMONSTRATION



- 1.Sliding motor
- 2. Transmitter
- 3.Safety photo sensor
- 4.Flashing light

2.2 DESCRIPTION OF DEVICE

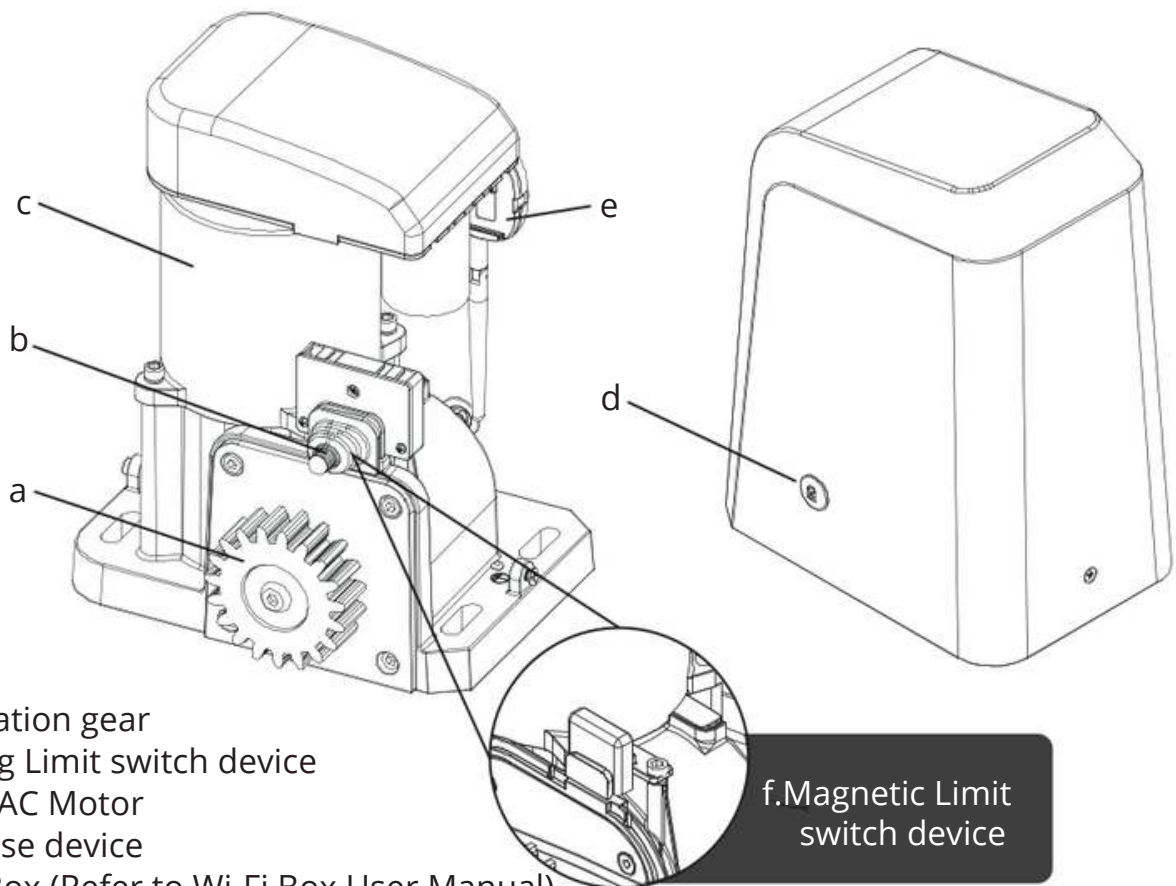

- a.Operation gear
- b.Spring Limit switch device
- c.230V AC Motor
- d.Release device
- e.Wifi Box (Refer to Wi-Fi Box User Manual)
- f.(Optional) Magnetic Limit switch device

2.3 DIMENSION OF DEVICE

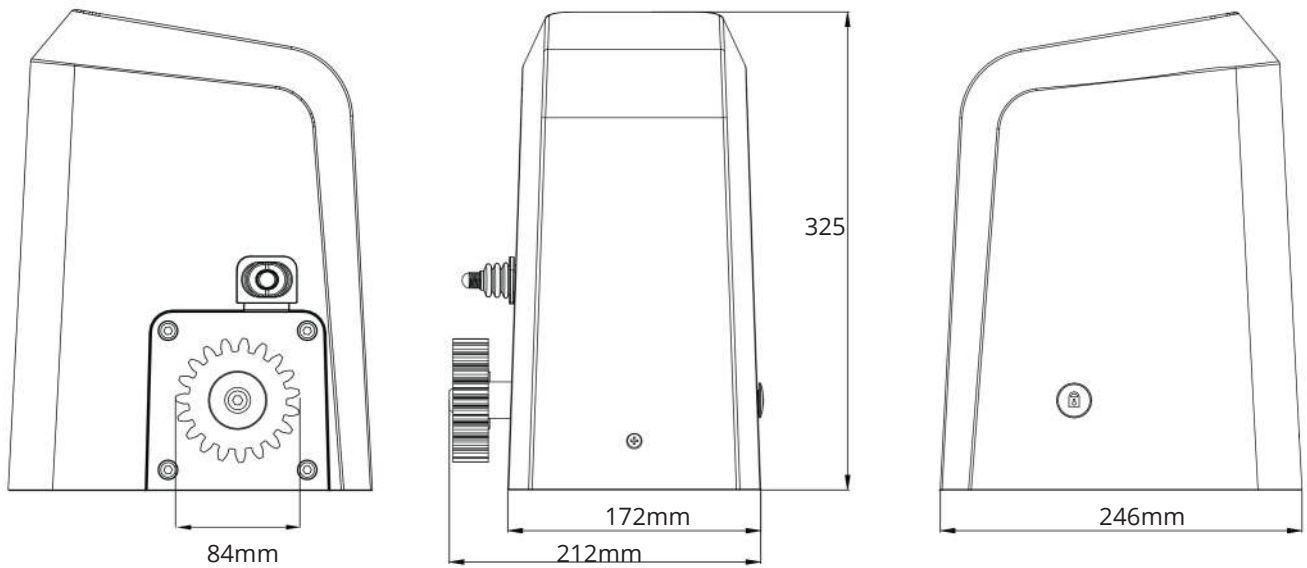

2.4 INSTALLATION OF MOTOR GEAR AND GEAR RACK

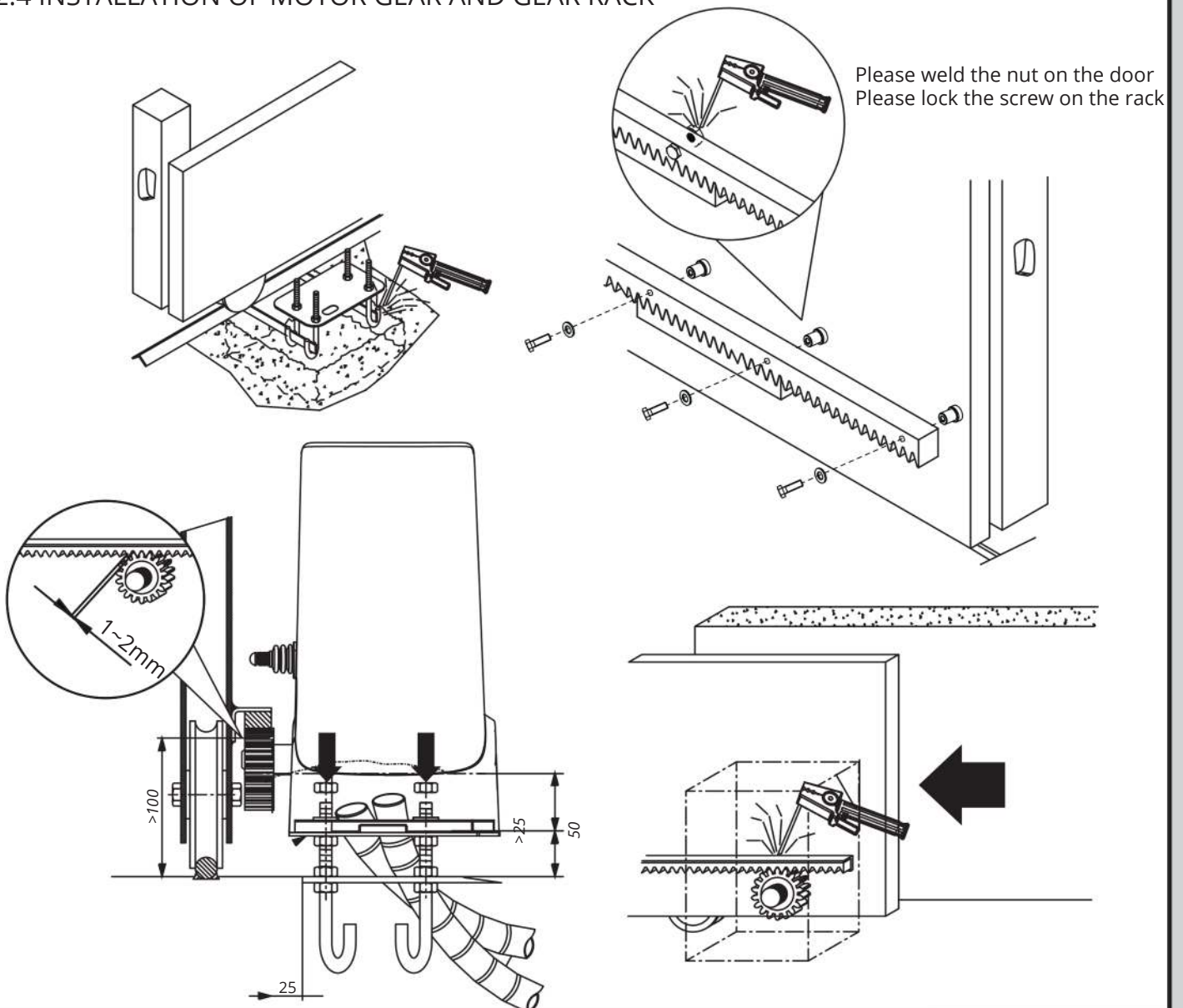

2.5 CHECKING FOR INSTALLATION

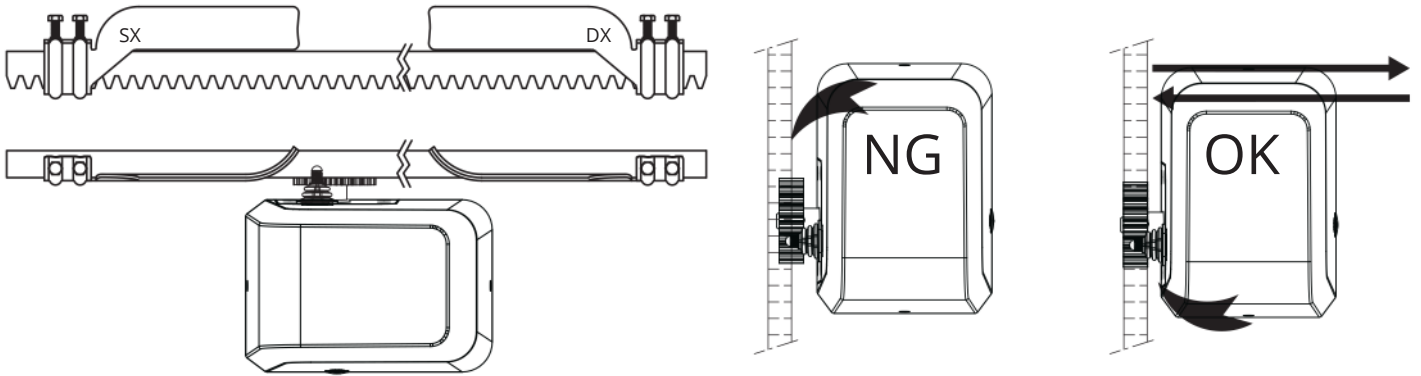

2.6 EMERGENCY RELEASE

In the case of power failure for emergency release of the motor, please follow the procedure as below:

Step1. Remove the rubber cover and reveal the lock hole.

Step2. Use a Hex key to release the gear system.

Step3. Put the rubber cover back to the lock hole.

To restore the automation, simply repeat the above procedure.

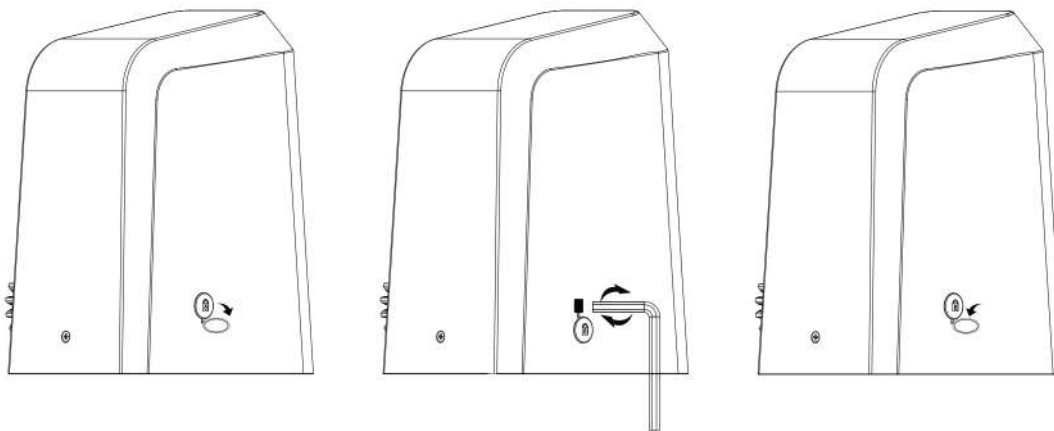

2.7 CONTROL BOARD

★Note 1 :

SW2_6 Wi-Fi MODE_ON : SW2 dip switch function on the control board will be disabled, please refer to the parameter setting by Chow APP.

★Note 2 :

The jumper between Terminal (7)&(10) can ONLY be removed while "(NC)device" be connected.

PB/GND and OPEN/GND terminals are for wired push button or key selector.

PB/GND: Open/Stop/Close/Stop
OPEN/GND : Open only

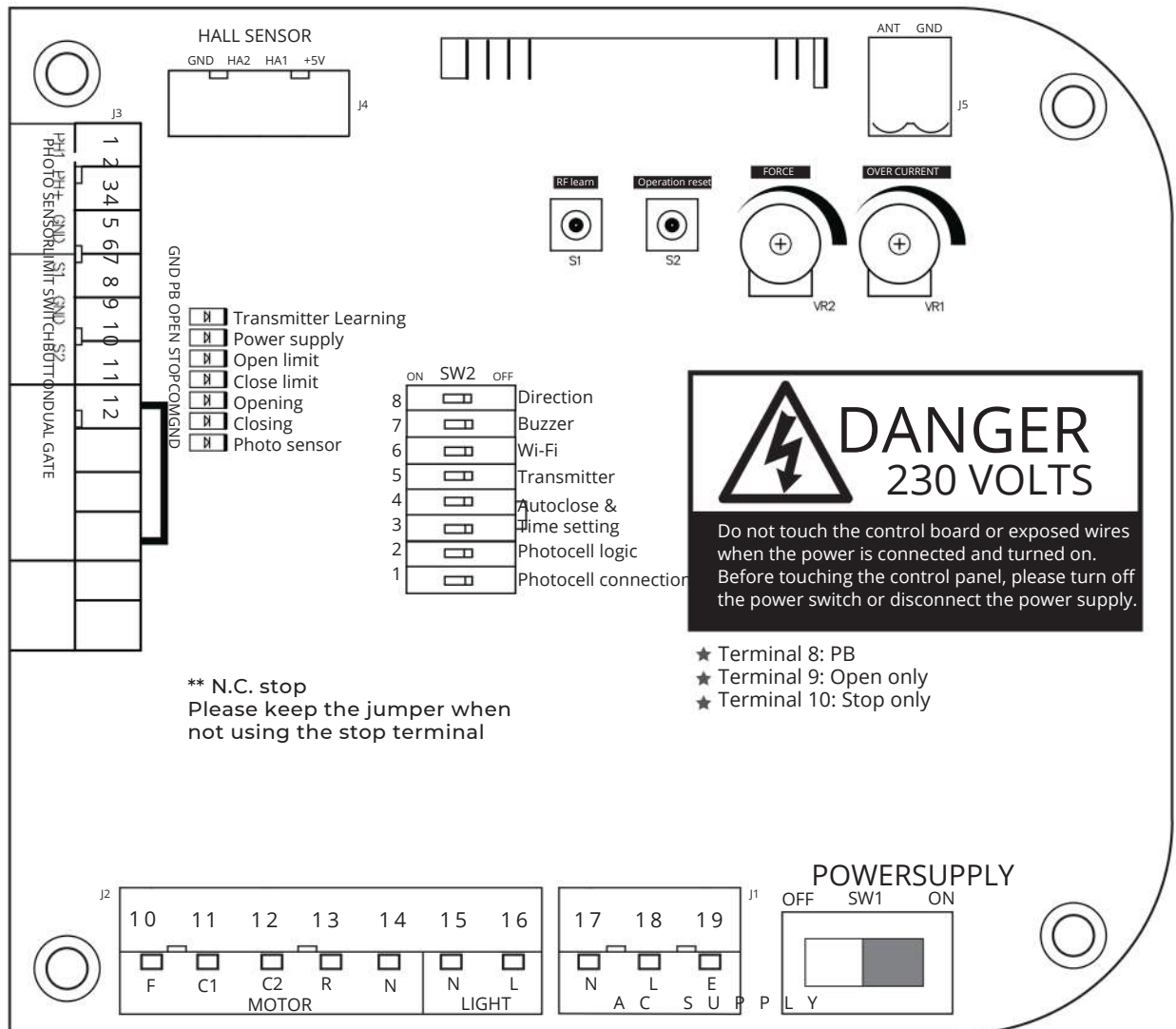
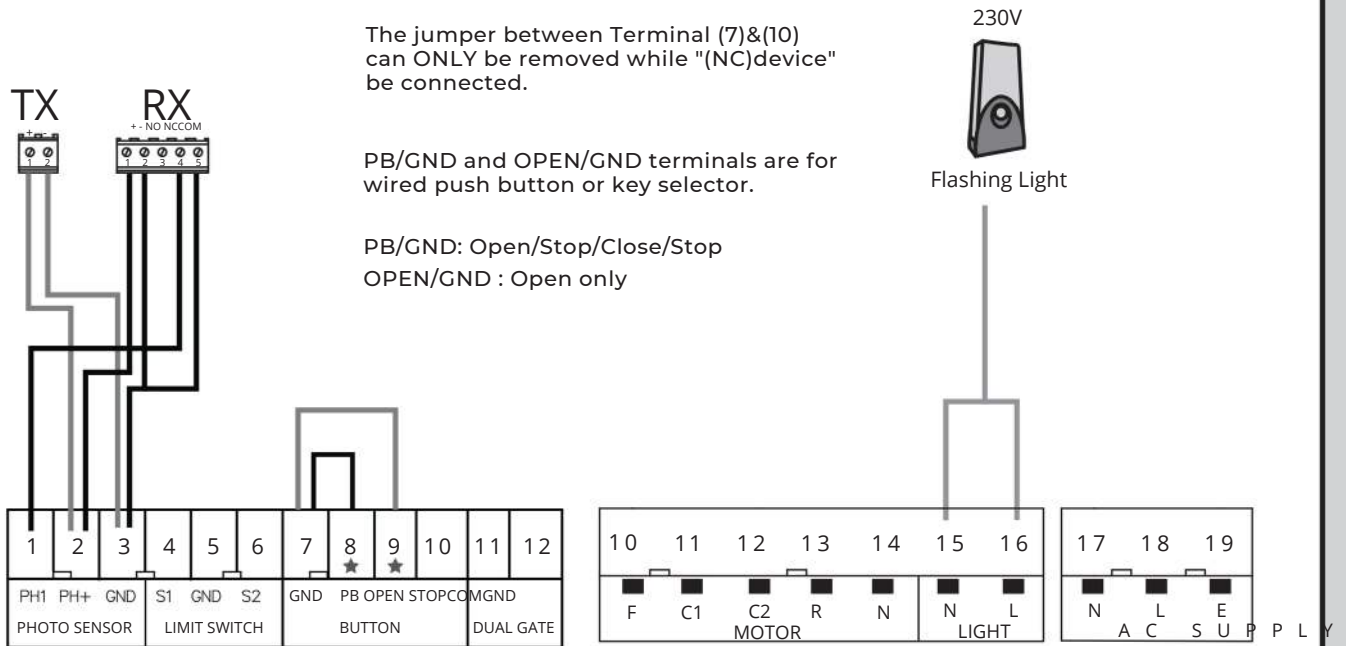

3). SETTING OF A CONTROL BOARD

ON	SW2	OFF
8		
7		
6		
5		
4		
3		
2		
1		

SW2

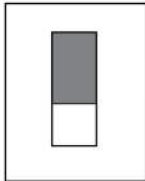

SW1

SW1	Power Supply	Photocell
SW2_1	Activation	Safety Device
SW2_2	Function Mode	Auto-Closing
SW2_3	Auto-Closing	Remote Mode
SW2_4	Wi-Fi	Alarm Buzzer
SW2_5	Operation	Direction
SW2_6		
SW2_7		
SW2_8		

3.1 SW1 DIP SWITCH SETTING – POWER SUPPLY
 ON: Power Supply ON, the control board can be operated.
 OFF: Power Supply OFF

3.2 SW2_1 PHOTOCELL ACTIVATION (REFER TO 7.PHOTOCELL INSTALLATION GUIDE)
 Warning:
 Please check the photocells are connected to the control panel properly before start. Otherwise, the motor will stop or view as triggered if the SW-1 is on.
 ON: Photocells function On and the photocells can be triggered.
 OFF: Photocells function OFF.

3.3 SW2_2 SAFETY DEVICE FUNCTION MODE
 ON: When opening – No effect. The gate continues opening to the end.
 When closing - The gate will stop immediately and reverse direction to the end if an obstacle is detected.
 OFF: When opening – No effect. The gate continues opening to the end.
 When closing - The gate will stop immediately if an obstacle is detected.





3.4 SW2_3, SW2_4 AUTO-CLOSING
 (1)SW2_3 OFF; SW2_4 OFF: Auto-Closing is OFF (2)SW2_3 ON; SW2_4 OFF: Auto-Closing is ON, gate closes automatically after 15 seconds. (3)SW2_3 OFF; SW2_4 ON: Auto-Closing is ON, gate closes automatically after 30 seconds. (4)SW2_3 ON; SW2_4 ON: Auto-Closing is ON, gate closes automatically after 60 seconds.

3.5 SW2_5 REMOTE MODE
 ON: A Key : OPEN – STOP – CLOSE – STOP. B, C Keys : No function. D key : Pedestrian mode(20% of full operation)
 OFF: A Key “OPEN”, B Key “STOP”, C Key “CLOSE”, D key “Pedestrian mode” (20% of full operation)
 A+D keep pushing 10 seconds, motor will be forcibly “Open” to the end.
 C+D keep pushing 10 seconds, motor will be forcibly “Close” to the end.
 Above, if the motor stop or the photocell is not function can be use A+D or C+D key.

3.6 SW2_6 WI-FI MODE(Refer to WB2 box User manual)
 ON: Wi-Fi function is on ★ Function ON : SW2 dip switch function on the control board will be disabled
 OFF: Wi-Fi function is off please refer to the parameter setting by Chow APP.

3.7 SW2_7 ALARM BUZZER
 ON: Buzzer is on. (While motor is running, the buzzer will also beep.)
 OFF: Buzzer is off

3.8 SW2_8 OPERATION DIRECTION
 ON : Open to RIGHT.
 OFF: Open to LEFT.

3.9 VR ADJUSTABLE VR KNOBS

VR1 : Over Current Adjustment: Turning clockwise to increase.

VR2 : Force adjustment: Turning clockwise to increase.

Step1. Please turn VR1 & VR2 clock-wisely to the maximum. The force at this stage is with max. torque.

Step2. Force adjustment: Please turn VR2 counter clock-wisely until the gate could be stopped easily by hand, and the motor is still working.

Step3. Over Current Adjustment: Please turn VR1 counter clock-wisely until opening gate and working motor be stopped.



4). TRANSMITTER SETTING AND SYSTEM LEARNING

4.1 TRANSMITTER SETTING

a.Remote learning: Press S1 3 seconds to enter transmitter learning mode and LED1 is on. Please press the left button (A button) on transmitter in 10 seconds, LED1 blinks twice and keeps on. After LED1 goes off (about 10 sec.) remote learning completes.

b.Cleaning the remote memories: Press S1 until LED1 goes off (about 10 sec.) After 10 sec., LED1 blinks 5 times and off. The Remote memories are removed.

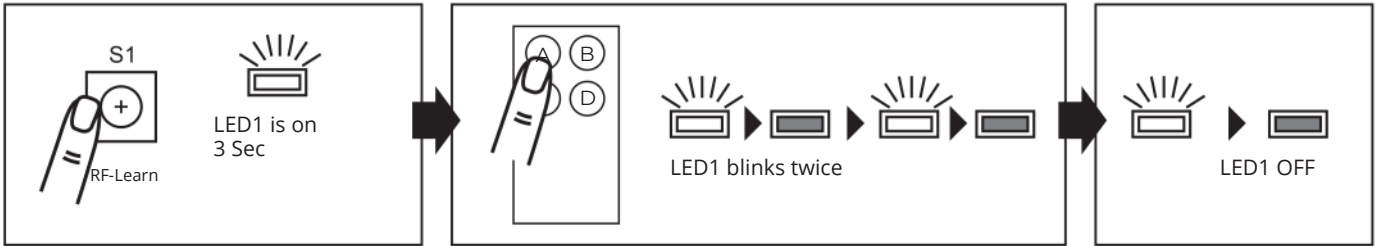

4.2 SYSTEM LEARNING

•Step 1. Before starting system learning, please manually release the motor and move the gate to the middle / half-open position.

SW2_8 OPERATION DIRECTION_OFF

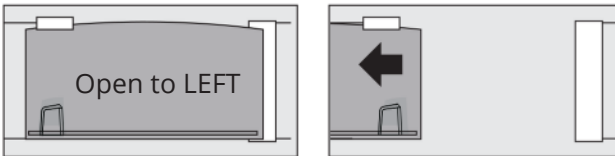

•Step 2.Press the button (A) on the remote control to start system learning. The gate will move to fully open position.

•Step 3.Press the button (C) on the remote control. The gate will move to fully closed position.

•Step 4. Each operation during system learning from open to closed or closed to open position must be completed within 150 seconds. Otherwise the motor will stop to prevent the overheat status.

•Step 5. System learning completed.

Reset System Learning :

Press the button "S2" for 5 seconds, the LED1 blinks 3 times indicating that the previous system learning is reinitialized. The motor should be operated by following the system learning process from Step 1 to Step 5 as above.

4.3 TRANSMITTER COPY

Press the A/B button on the learned transmitter more than 3 seconds. When the buzzer sound is heard, please press any button on the new remote for 2 seconds to copy the setting. If no connecting with new remotes for more than 10 seconds, the remote copy system will end automatically.

4.4 GATE OPERATING

Press A/D button on remote for 10 seconds, keep pressing will activate the motor compulsively. (Compulsively opening operation is applicable for motor with obstacle and photocells error)

Press C/D button on remote for 10 seconds, keep pressing will activate the motor compulsively. (Compulsively closing operation is applicable for motor with obstacle and photocells error)

5). OTHER FUNCTION

5.1 LED INDICATIONS

LED	Function	LED Color
LED1	transmitter and system learning indicator	RED
LED2	Power Supply	RED
LED3	Motor meets open limit	GREEN
LED4	Motor meets close limit	RED
LED5	Opening	GREEN
LED6	Closing	RED
LED7	Photocells	RED

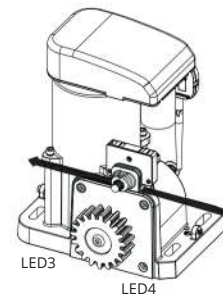

5.2 DECELERATION FUNCTION

The 5% of the final stroke is the deceleration zone. The gate moves with 20% full speed till closed or limit switch is triggered.

5.3 GATE-MOVING LOGIC

(A) In gate opening/closing phrase: For safety concern, opening/closing gate stops when running into obstacle
 (B) Initial system working and the first operating of the corrective motor, motor closes 10 seconds with full speed, then move with decelerated speed till limit-switch triggered. The system will memorize each operating time and also adjusting the decelerated area.

5.4 WIRES CONNECTING FOR TWO GATES / OPERATING

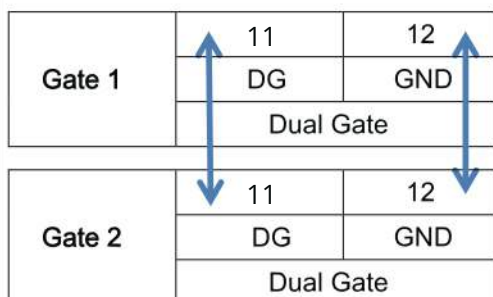

Connecting the terminal (DG and GND) on both control boards with 2 x 0.75m cable (see left figure), which could open both gates. Transmitter only needs to do the system learning with one motor. When pressing the transmitter, both motors will operate at the same time.

6). TECHNICAL CHARACTERISTICS:

6.1 TECHNICAL DATA SHEET OF HUSKY SERIES

Specification	HUSKY700	HUSKY1200	HUSKY1500
	700KG Series	1200KG Series	1500KG Series
Power Supply	AC230V 50Hz	AC230V 50Hz	AC230V 50Hz
Max. gate weight	700kg	1200kg	1500Kg
Max. gate speed	19.78 m/second	19.78 m/second	15.62cm/second
Limit Switch	Spring / Magnetic	Spring / Magnetic	Spring / Magnetic
Temperature	-20°C ~ +65°C	-20°C ~ +65°C	-20°C ~ +65°C
Protection Class	IP 54	IP 54	IP 54

6.2 TRANSMITTER DATA SHEET

Application	Radio Transmitter
Frequency	433.9Mhz
Coding	Rolling Code
Buttons	4 Buttons
Power Supply	3V with one CR2032 button type lithium battery
Operating Temperature	-20°C ~ +50°C
Dimension	71.5mm * 33mm * 14mm

7).PHOTOCELL INSTALLATION GUIDE

The safety photocells are security devices for control automatic gates. Consist of one transmitter and one receiver based in waterproof covers; it is triggered while breaking the path of the beams.

SPECIFICATION:

Detection Method	Through Beam MAX~15m
Sensing Range Input	AC/DC 12~24V
Voltage Contact	
Current Response Time	TX: 30mA Max , RX: 25 mA Max
Emitting Element	<100mS Infrared LED/ Wave
Operation Indicator	Length: 940nm
	RX: Red LED On (beam broken) / Off (beam aligned)
	TX: Red LED On 63*63*30 mm
Dimensions	
Output Method	Relay Output Beam aligned :
Current Consumption	RX<25ma\TX<30ma Beam broken: RX <10ma\TX <30ma
Connection Method	Terminal Block ABS / PC IP44
Housing Material	CE
Water Proof	
Safety Standard	

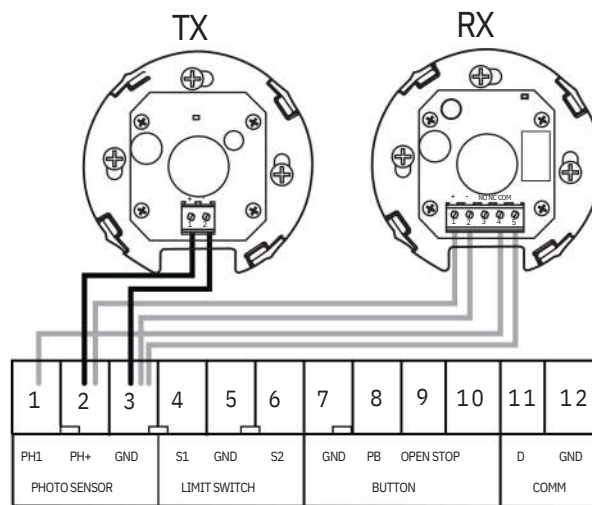
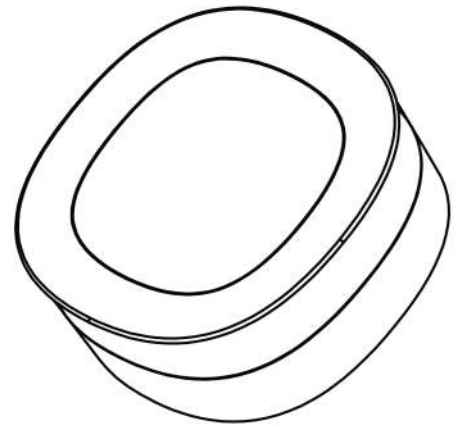

INSTALLATION:

1. Open the cover and connect wire

TX: Connect the terminals +, - on the transmitter with the terminals PH+, GND on PCB.

RX: Connect the terminals +, -, NC, COM on the receiver with the terminals PH+, GND, PH1, GND on PCB.

2. Mount the receiver and transmitter on the proper positio

3. Ensure there are no obstacles between receiver and transmitter. For optional efficiency, the receiver and transmitt should be properly aligned.

4. Power-up the photocells and make sure LED light on receiver a

5. Transmitter are O

Step 1

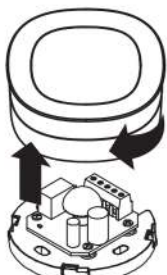

Step 2

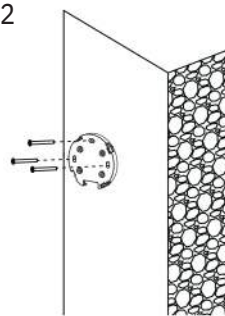

Step 3

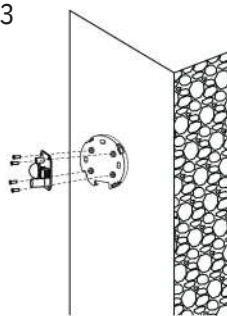

Step 4

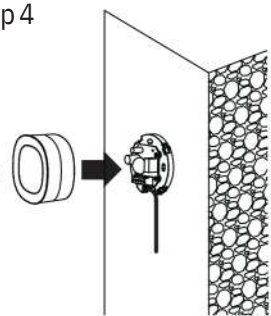

+212666-453-856



+212522-502-539