

AT PLUS-2500



ENG

Manual for installation and maintenance of automatism for sliding gates.

WARNINGS FOR THE INSTALLER

GENERAL SAFETY OBLIGATIONS

- 1) ATTENTION! To ensure the safety of people, it is important that you read all the following instructions. Incorrect installation or incorrect use of the product could cause serious harm to people.
- 2) Carefully read the instructions before beginning to install the product.
- 3) Do not leave packing materials (plastic, polystyrene, etc.) within reach of children as such materials are potential sources of danger.
- 4) Store these instructions for future reference. 5) This product was designed and built strictly for the use indicated in this documentation. Any other use, not expressly indicated here, could compromise the good condition/operation of the product and/or be a source of danger.
- 6) VDS declines all liability caused by improper use or use other than that for which the automated system was intended.
- 7) Do not install the equipment in an explosive atmosphere: the presence of inflammable gas or fumes is a serious danger to safety.
- 8) The mechanical parts must conform to the provisions of Standards EN 12604 and EN 12605. For non-EU countries, to obtain an adequate level of safety, the Standards mentioned above must be observed, in addition to national legal regulations.
- 9) VDS is not responsible for failure to observe Good Technique in the construction of the closing elements to be motorised, or for any deformation that may occur during use.
- 10) The installation must conform to Standards EN 12453 and EN 12445. For non-EU countries, to obtain an adequate level of safety, the Standards mentioned above must be observed, in addition to national legal regulations.
- 11) Before attempting any job on the system, cut out electrical power.
- 12) The mains power supply of the automated system must be fitted with an all-pole switch with contact opening distance of 3mm or greater. Use of a 6A thermal breaker with all-pole circuit break is recommended.
- 13) Make sure that a differential switch with threshold of 0.03 A is fitted upstream of the system.
- 14) Make sure that the earthing system is perfectly constructed, and connect metal parts of the means of the closure to it.
- 15) The safety devices (EN 12978 standard) protect any danger areas against mechanical movement Risks, such as crushing, dragging, and shearing.
- 16) Use of at least one indicator-light is recommended for every system, as well as a warning sign adequately secured to the frame structure, in addition to the safety devices.
- 17) VDS declines all liability as concerns safety and efficient operation of the automated system, if system components not produced by VDS are used.
- 18) For maintenance, strictly use original parts by VDS
- 19) Do not in any way modify the components of the automated system.
- 20) The installer shall supply all information concerning manual operation of the system in case of an emergency, and shall hand over to the user the warnings handbook supplied with the product.
- 21) Do not allow children or adults to stay near the product while it is operating.
- 22) Keep radiocontrols or other pulse generators away from children, to prevent the automated system from being activated involuntarily.
- 23) The user must not attempt any kind of repair or direct action whatever and contact qualified personnel only.
- 24) Transit is permitted only when the automated system is idle.
- 25) Maintenance: check at least every 6 months the efficiency of the system, particularly the efficiency of the safety devices (including, where foreseen, the operator thrust force) and of the release devices.
- 26) Anything not expressly specified in these instructions is not permitted.

MOTOR AT 2500

These instructions apply to the following models: AT-2500
The automatism AT-2500 gearmotor is an electro-mechanical operator designed for moving sliding gates.

The non-reversing reduction system ensures the gate is mechanically locked when the gearmotor is not operating, therefore it is not necessary to install any electric lock. A convenient manual release with customised key makes it possible to move the gate in the event of a power failure or malfunction of the operator.

The AT-2500 gearmotor was designed and built for controlling vehicle access.

AVOID ANY OTHER USE WHATEVER.

where:

T_a = opening time

T_c = closing time

T_p = pause time

T_i = time of interval between two complete cycles

1. DESCRIPTION AND TECHNICAL SPECIFICATIONS

1.1. DIMENSIONS AT-2500

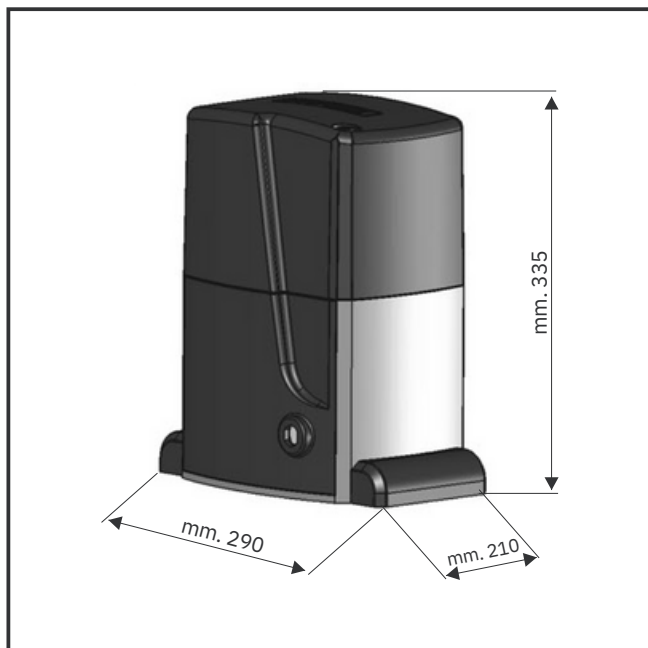

1.2. MAXIMUM USE CURVE

The curve makes it possible to establish maximum work time (T) according to use frequency (F). With reference to IEC 34-1 Standard, the AT-2500 gearmotor can operate at a use frequency of 40%.

To ensure efficient operation, it is necessary to operate in the work range below the curve.

Important: The curve is obtained at a temperature of 20°C. Exposure to the direct sun rays can reduce use frequency down to 20%.

Calculation of use frequency

Use frequency is the percentage of effective work time (opening + closing) compared to total time of cycle (opening + closing + pause times). Calculation formula:

$$\% = \frac{T_a + T_c}{T_a + T_c + T_p + T_i} \times 100$$

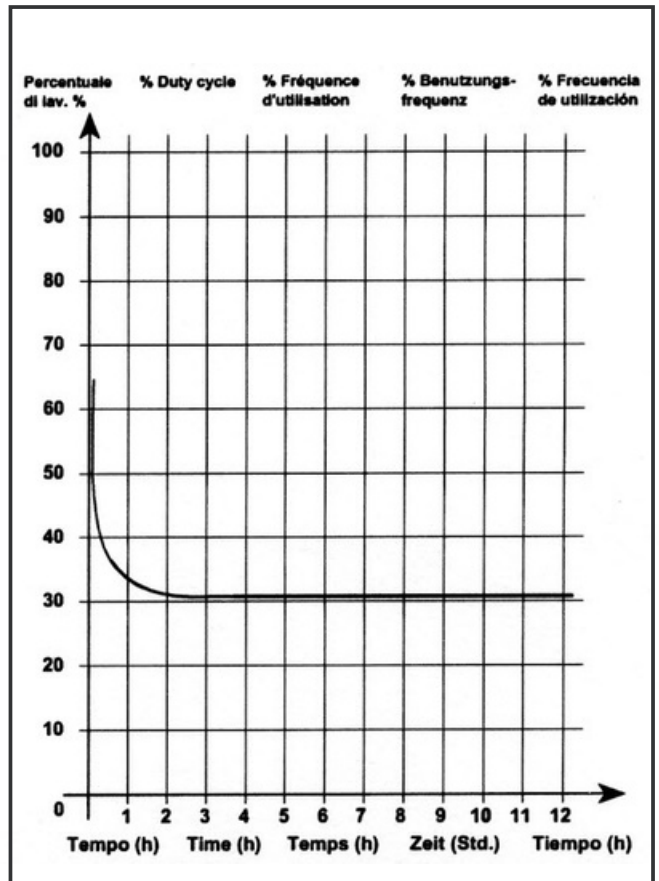

1.3. TECHNICAL SPECIFICATIONS

MODEL AT-2500

	Monophase	Tree phase
Power supply	230V (+6% -10%) 50Hz	380V (+6% -10%) 50Hz
Absorbed power (W)	650	
RPM (X min.)	1400	
Absorbed current (A)	2,4	
Capacitor	25 uf	/
Reduction Ratio	1:30	
Pinion	Modulo 4 - Z16	
Thrust on pinion (daN)	170	
Winding thermal protection	130°C	
Use frequency	Intensive use	
Oil quantity (Lt)	1	
Oil type	Total Equivis HZS 68	
Operating temperature	-20°C +55°C	
Gearmotor weight (Kg)	17	
Protection class	IP 44	
Gate max weight (Kg)	2500	
Gate speed	9,6 ml/min.	
Clutch	Double disc in oil	

2. ELECTRICAL SET-UP (standard system)

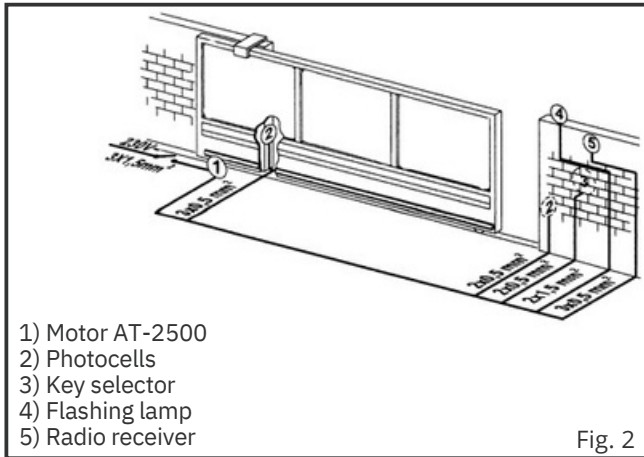

3. INSTALLING THE AUTOMATISM

3.1. Preliminary checks

To ensure safety and efficiency of the automated system, make sure the following requirements are observed before installing the system:

- The gate structure must be suitable for automation. The following are necessary in particular: wheel diameter must be in proportion to the weight of the gate, an upper track must be provided, plus mechanical travel stops to prevent the gate derailing.
- The soil must guarantee a perfect stability of the foundation plinth.
- There must be no pipes or electric cables in the plinth excavation area.
- If the gearmotor is located in the vehicle transit or manoeuvre area, adequate means of protection should be provided against accidental impact.
- Check if an efficient earthing is available for connection to the gearmotor.

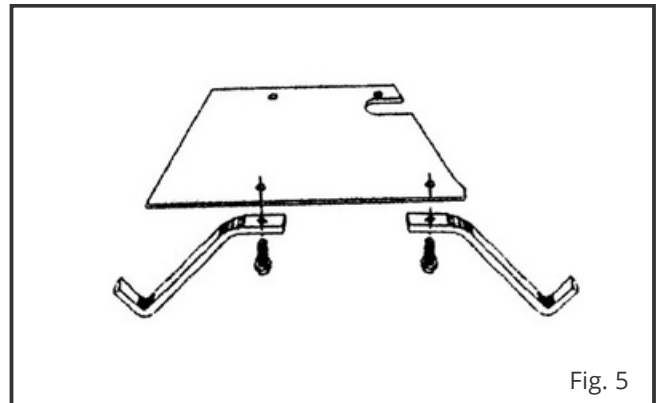
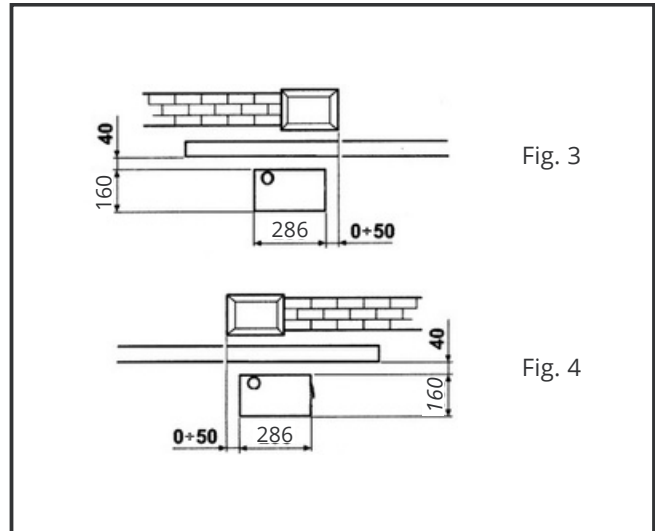

3.2. MASONRY FOR FOUNDATION PLATE

1- Assemble the foundation plate as shown in figure 05. 2- In order to ensure that the pinion and rack engage correctly, the foundation plate must be positioned as shown in Fig. 03 (right closing) or Fig. 04 (left closing). Warning: The hole for the cables on the foundation plate must always point to the gate, see Fig. 05. 3- After determining the position of the foundation plate, make a plinth as shown in Fig. 06 and wall the plate, providing several sheaths for routing the cables. Using a spirit level, check if the plate is perfectly level. Wait for the cement to set. 4- Lay the electric cables for connection to the accessories and power supply as shown in diagram of Fig. 02. To facilitate connections to the control unit, allow the cables to protrude by at least 45 cm from the hole on the foundation plate.

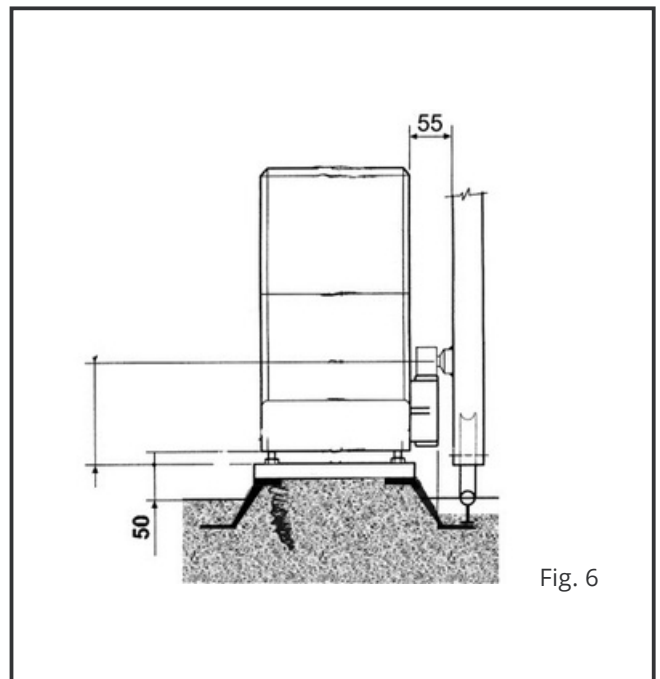

3.3. MECHANICAL INSTALLATION

1- Remove the cover and position the operator on the foundation plate, using the supplied washers and nuts. During this operation, route the cables through the appropriate openings in the motor body. 2- Adjust the height of the gearmotor and the distance from the gate, referring to dimensions in Fig. 6. Attention: This operation is necessary to ensure the rack is correctly secured and to enable any new adjustments. 4- Secure the gearmotor to the plate, tightening the nuts.

3.4. ASSEMBLING THE RACK

3.4.1. STEEL RACK TO WELD (fig.7)

1) Fit the three threaded pawls on the rack element, positioning them at the bottom of the slot. In this way, the slot play will enable any future adjustments to be made. 2) Manually take the leaf into its closing position. 3) Lay the first section of rack level on the pinion and weld the threaded pawl on the gate. 4) Move the gate manually, checking if the rack is resting on the pinion, and weld the second and third pawl. 5) Position another rack element end to end with the previous one, using a section of rack to synchronise the teeth of the two elements. 6) Move the gate manually and weld the three threaded pawls, thus proceeding until the gate is fully covered.

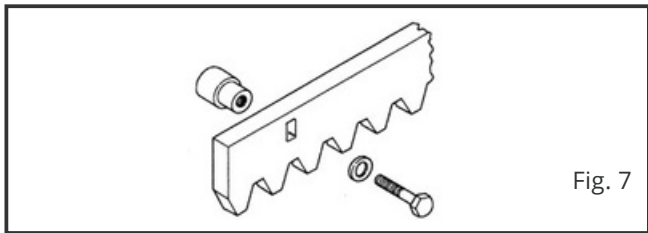

Fig. 7

3.4.2. STEEL RACK TO SCREW (fig. 8)

1) Manually take the leaf into its closing position. 2) Lay the first section of rack level on the pinion and place the spacer between the rack and the gate, positioning it at the bottom of the slot. 3) Mark the drilling point on the gate. Drill a Ø 6,5 mm hole and thread with an M8 male tap. Screw the bolt. 4) Move the gate manually, checking if the rack is resting on the pinion, and repeat the operations at point 3. 5) Position another rack element end to end with the previous one, using a section of rack to synchronise the teeth of the two elements. 6) Move the gate manually and carry out the securing operations as for the first element, thus proceeding until the gate is fully covered.

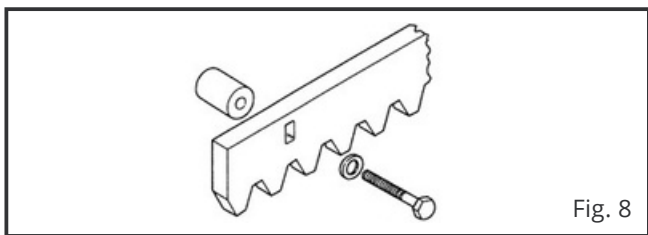

Fig. 8

3.4.3. NYLON RACK TO SCREW (fig. 9)

1) Manually take the leaf into its closing position. 2) Lay the first section of rack level on the pinion. 3) Mark the drilling point on the gate. Drill a Ø 4 mm hole and thread with screw 6x20 mm with relative plate reinforcement. 4) Move the gate manually, checking if the rack is resting on the pinion, and repeat the operations at point 2. 5) Position another rack element end to end with the previous one, using a section of rack to synchronise the teeth of the two elements. 6) Move the gate manually and carry out the securing operations as for the first element, thus proceeding until the gate is fully covered.

NOTES ON RACK INSTALLATION • Make sure that, during the gate travel, all the rack elements do not exit the pinion. • Do not, on any account, weld the rack elements either to the spacers or to each other.(only for steel rack). • When the rack has been installed, to ensure it meshes correctly with the pinion, it is advisable to lower the gearmotor position by about 1.5 mm. • Manually check if the gate correctly reaches the mechanical limit stops maintaining the pinion and rack coupled and make sure there is no friction during gate travel. • Do not use grease or other lubricants between rack and pinion.

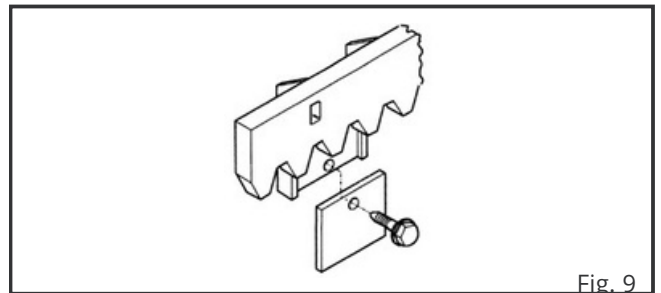

Fig. 9

4. START UP

4.1. CONTROL BOARD CONNECTION

ATTENTION:

Before attempting any work on the board (connections, programming, maintenance), always turn off power.

4.2. ADJUSTING THE TORQUE TRANSMISSION (only for AT 2500)

To adjust the torque transmission, act on the screw placed on the engine (Fig. 10): - Rotate the screw clockwise to increase the torque transmission. - Rotate the screw anticlockwise to decrease the torque transmission. CAUTION: THE MOTOR IS PROVIDED WITH THE CLUTCH REGULATED AT MAX. SHOULD BE ROTATE ANTICLOCKWISE THE SCREW, UP TO ACHIEVE THE OPTIMAL ADJUSTMENT.

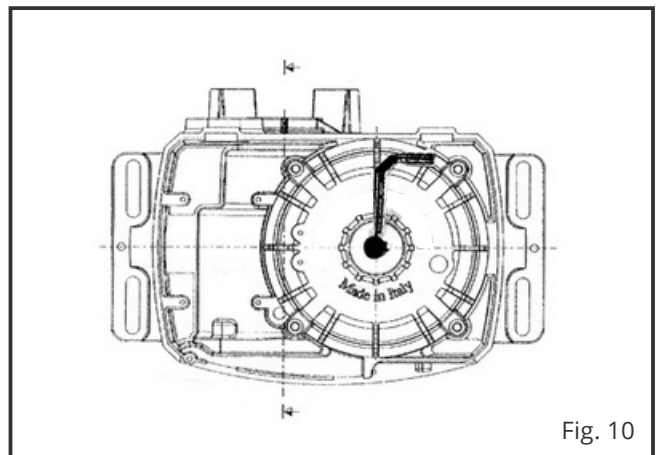

Fig. 10

4.3. AUTOMATISM SYSTEM TEST

Once installation of the operator has been completed, make a careful functional check of all accessories and safety devices connected.

Give the Client the “User Guide” and demonstrate the correct operation and use of the gearmotor, highlighting the potentially dangerous zones of the automated system.

5. MANUAL OPERATION

If it is necessary to manually actuate the gate due to lack of power or disruption of automation, you must act on the release as follows.

LEVER UNLOCK

- 1) Insert the key supplied in the plastic fold and open it.
- 2) Pull the lever unlock.
- 3) Open or close the gate manually.

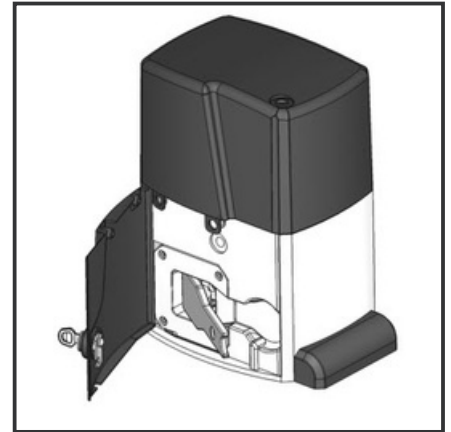

6. RESTORING NORMAL OPERATION

To prevent an inadvertent boost could move the gate during the maneuver, turn off the power supply , before locking again the motor.

LEVER UNLOCK

- 1) Close the unlock lever.
- 2) Move the gate until the release system meshes.
- 3) Close the plastic fold and restore the power supply to the system

7. MAINTENANCE

Check the functional operation of the system at least every six months, especially the efficiency of the safety devices (including the operator thrust force) and the release devices.

7.1. OIL FILLING

Periodically check the amount of oil within the operator.

For medium-low frequency of use, an annual check is enough, for more intensive use it is recommended every 6 months.

To make filling, unscrew the cap and load until the level.

8. REPAIRS

For any repairs, contact VDS authorised Repair Centres.

AT-2500

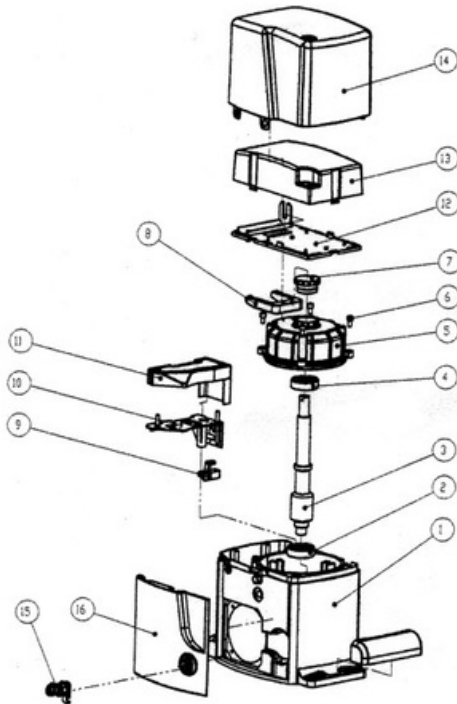

SPARE PARTS

1	Body reducer
2	Bearing 6303
3	Crankshaft
4	Bearing 6303
5	Motor cover
6	Screw TCEI 6 x 12
7	Register clutch cap
8	Electronic box hinge
9	Support spring limit switch
10	Limit switch box base
11	Limit switch cover
12	Electric box base
13	Electric box cover
14	External cover
15	MSC
16	Fold lock

TRANSMISSION AND UNLOCK GROUP

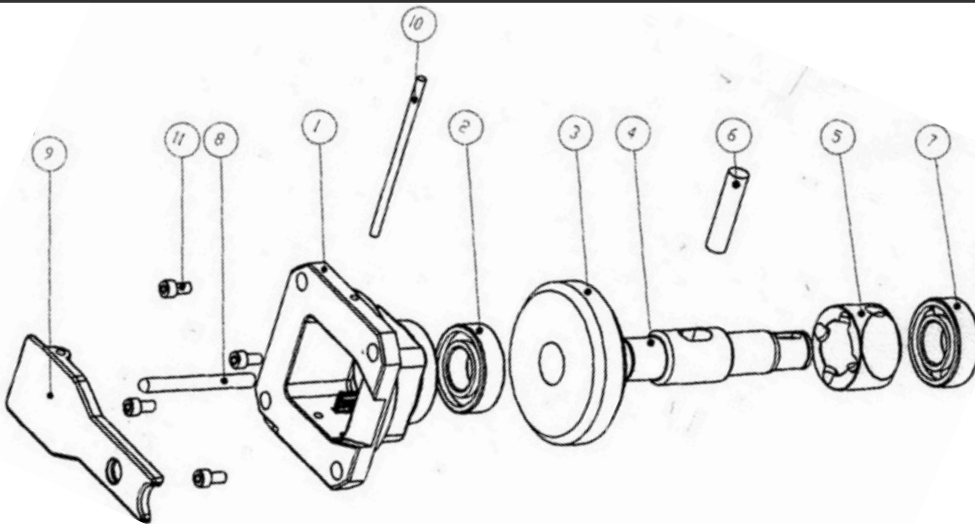

1	Square cap
2	Bearing 6205
3	Helical wheel
4	Led tree
5	Unlock Coupling
6	Plug 12 X 47
7	Bearing 6205
8	Unlock pin 8 x 80,5
9	Unlock lever
10	Unlock lever plug 5 X 106
11	Screw TCEI 6 X 12

Timbro del Rivenditore:/Distrlbutor's Stamp:/Timbre de l'Agent:/ Fachhandlerstempel/Sello del Revendedor:

USER'S GUIDE

MOTOR FOR SLIDING GATE MOD. AT 2500

Read the instructions carefully before using the product and keep them for future consultation.

GENERAL SAFETY RULES

If installed and used correctly, the AT-2500 automated system will ensure a high degree of safety. Some simple rules regarding behaviour will avoid any accidental trouble:

- Do not stand near the automated system and do not allow children and other people or things to stand there, especially while it is operating.
- Keep radiocontrols or any other pulse generator well away from children to prevent the automated system from being activated involuntarily.
- Do not allow children to play with the automated system.
- Do not willingly obstruct gate movement.
- Prevent any branches or shrubs from interfering with gate movement.
- Keep light signalling systems efficient and clearly visible.
- Do not attempt to activate the gate by hand unless you have released it.
- In the event of malfunctions, release the gate to allow access and wait for qualified technical personnel to do the necessary work.
- After enabling manual operation, switch off the power supply to the system before restoring normal operation.
- Do not make any alterations to the components of the automated system.
- Do not attempt any kind of repair of direct action whatsoever and contact qualified personnel only.
- Call in qualified personnel at least every 6 months to check the efficiency of the automated system, safety devices and earth connection.

MANUAL OPERATION

If it is necessary to manually actuate the gate due to lack of power or disruption of automation, you must act on the release as follows. LEVER UNLOCK 1) Insert the key supplied in the plastic fold and open it. 2) Pull the lever unlock. 3) Open or close the gate manually.

DESCRIPTION

The AT-2500 automated system is ideal for controlling vehicle access areas of medium transit frequency.
The AT-2500 automated system for sliding gates

All products are guaranteed for 2 years, as per the date on the invoice or on the receipt. The warranty also does not include: failures or damages caused by faults of the electrical system and/or carelessness, negligence or inadequacy of the installation to the use for which it is intended and in any case from abnormal use; failures or damages due to tampering by unauthorized personnel or the use of components not attributable to the manufacturer and/or non-original spare parts; defects caused by chemical agents, external bodies or atmospheric and/or natural phenomena in general; failures or damages caused by incorrect installation of the Products according to the rule of art, safety and conformity of use expressly indicated in the technical documentation of the same Products; the consumables; interventions for checks and assessments of any flaws or defects then not found; compensations for the period of inactivity of the system where the Products are installed.

The data and images are for guidance only

VDS reserves the right to change at any time characteristics of the products described in its sole discretion, without notice.



Via Circolare p.i.p. N° 10
65010 Santa Teresa di Spoltore (PE) - ITALY
Tel. +39 085 4971946 - FAX +39 085 4973849
www.vdsautomation.com - info@vdsautomation.it



 +212666-453-856

 +212522-502-539