



POLYOPEN
MAROC

www.polyopen.ma



marantec

drive technology



Instructions and warnings for installation and use
Anleitungen und Hinweise zu Installation und Einsatz
Istruzioni ed avvertenze per l'installazione e l'uso
Instructions et avertissements pour l'installation et l'usage
Instrucciones y advertencias para su instalación y uso
Instruções e advertências para a instalação e utilização
Instrukcje i zalecenia dotyczące instalacji i użytkowania

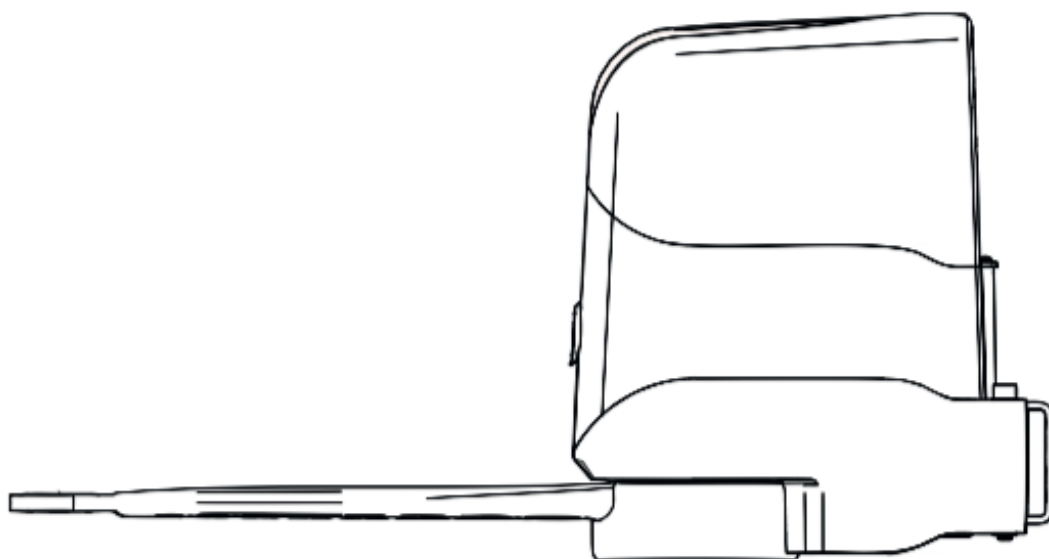

COMFORT REP

REP2224, REP2224S

Gear motor for hinged gates

Antriebe für Drehtore

Motoriduttore per cancelli a battente

Motoréducteur pour portails à battants

Motorreductor para cancelas batientes

Motorreduktors para portões de batente

Motoreduktor do bram skrzydłowych

IMAGES

Fig. 1 EN - Space dimensions
DE - Abmessungen
IT - Dimensioni d'ingombro
FR - Dimensions d'encombement

ES - Dimensiones
PT - Dimensões globais
PL - Wymiary

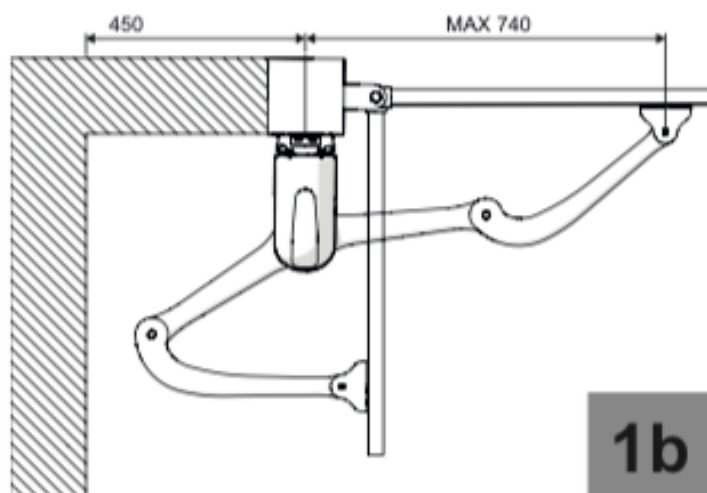
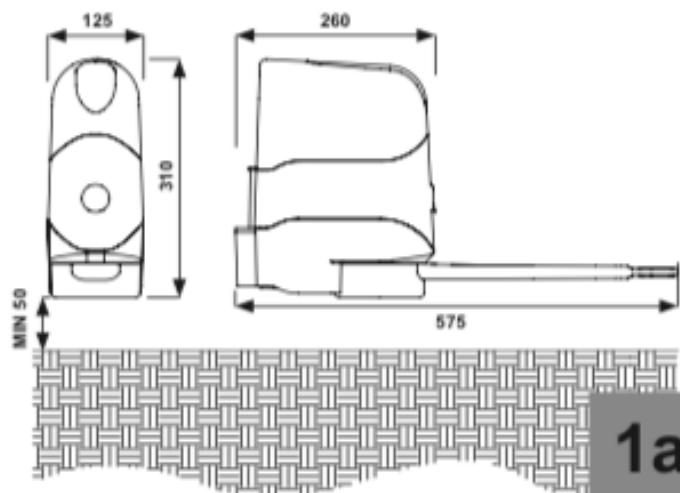
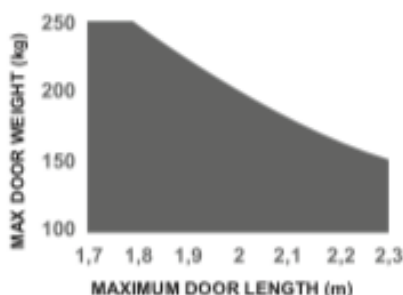

Fig. 2 EN - Use limitations
DE - Einsatzgrenzen
IT - Limiti di impiego
FR - Limites d'utilisation

ES - Límites de uso
PT - Limites de uso
PL - Ograniczenia użytkowania



KG

EN - Maximum weight of the gate door
DE - Maximales Gewicht des Torflügels
IT - Peso massimo dell' anta del cancello
FR - Poids maximum du battant du portail
ES - Peso máximo de la puerta de la cancela
PT - Peso máximo do painel do portão
PL - Waga maksymalna skrzydła bramy

m

EN - Maximum length of the gate door
DE - Maximale Länge des Torflügels
IT - Lunghezza massima dell' anta del cancello
FR - Longueur maximum du battant du portail
ES - Longitud máxima de la puerta de la cancela
PT - Comprimento máximo do painel do portão
PL - Długość maksymalna skrzydła bramy

Fig. 3 EN - Components
DE - Bauteile
IT - Componenti
FR - Composants

ES - Componentes
PT - Componentes
PL - Komponenty

- IT
- 1 - Braccio curvo
 - 2 - Braccio dritto
 - 3 - Staffa di fissaggio anta
 - 4 - Finecorsa
 - 5 - Coperchio finecorsa
 - 6 - Staffa di fissaggio a muro
 - 7 - Motoriduttore

- EN
- 1 - Curved arm
 - 2 - Straight arm
 - 3 - Door fixing bracket
 - 4 - Limit switch
 - 5 - Limit switch cover
 - 6 - Wall fixing bracket
 - 7 - Gearmotor

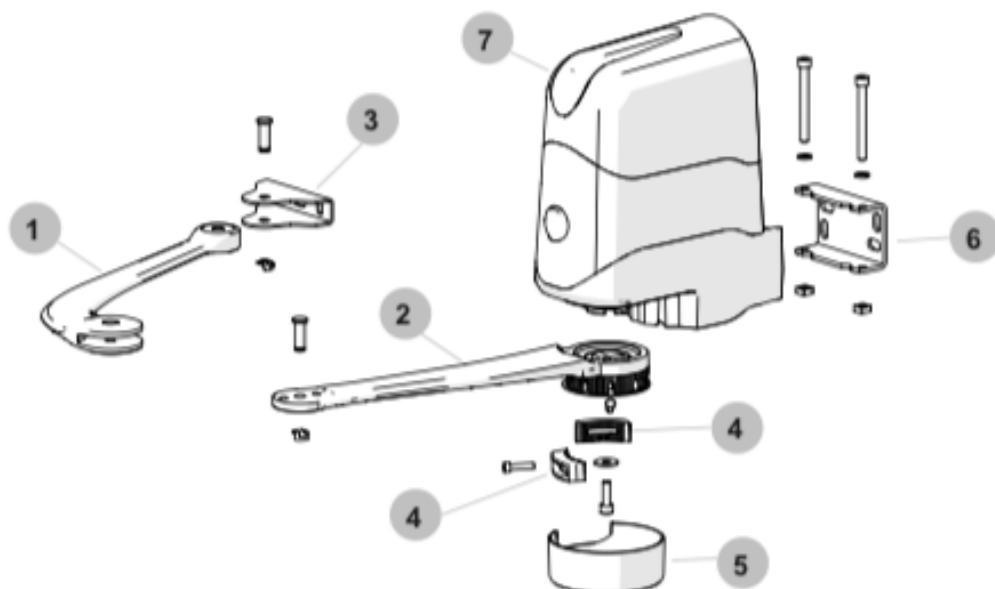

Fig. 4 EN - Quotes representation
 DE - Darstellung der Werte
 IT - Rappresentazione quote
 FR - Représentation hauteurs

ES - Representación cuotas
 PT - Quotas de representação
 PL - Przedstawienie wartości

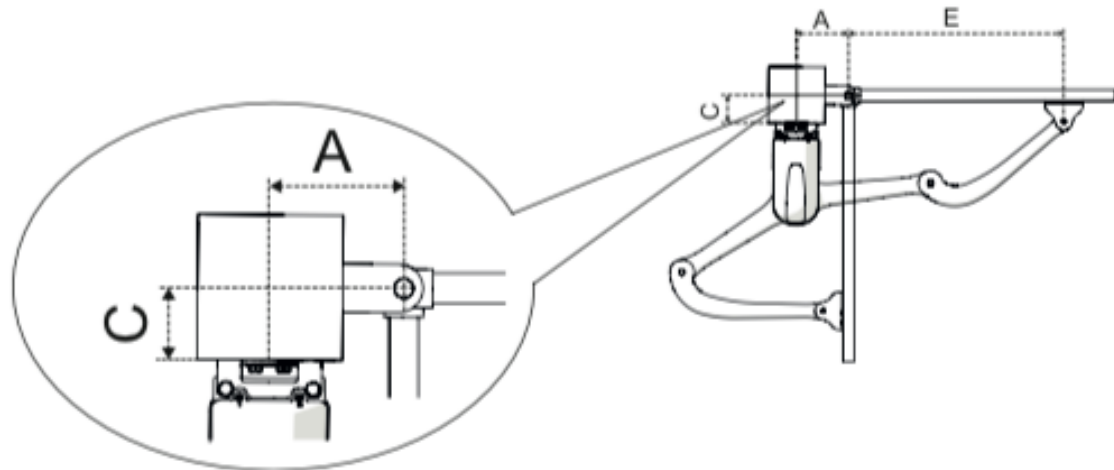

Fig. 5 EN - Opening angle graph
 DE - Zeichnung zum Öffnungswinke
 IT - Grafico angolo di apertura
 FR - Graphique angle d'ouverture

ES - Gráfico ángulo de apertura
 PT - Gráfico ângulo de abertura
 PL - Wykres kąta otwarcia

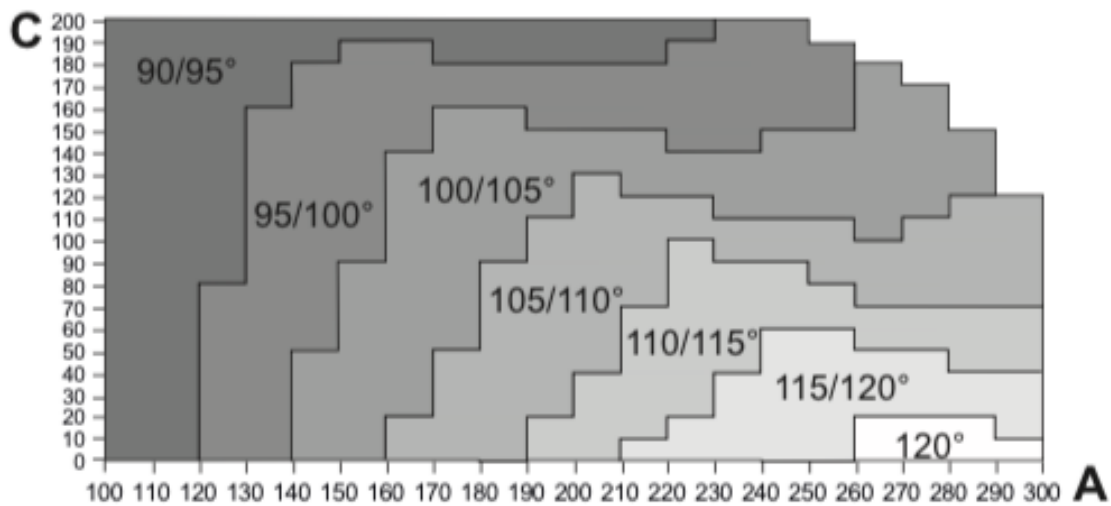

Fig. 6 EN - Typical Installation
 DE - Typische Installation
 IT - Installazione tipica
 FR - Installation type

ES - Instalación típica
 PT - Gráfico ângulo de abertura
 PL - Wykres kąta otwarcia



Fig. 7 EN - Positioning the motor
 DE - Positionierung des Antriebs
 IT - Posizionamento del motoriduttore
 FR - Positionnement moteur

ES - Colocación del motorreductor
 PT - Posicionamento do motorreductor
 PL - Położenie motoreduktora

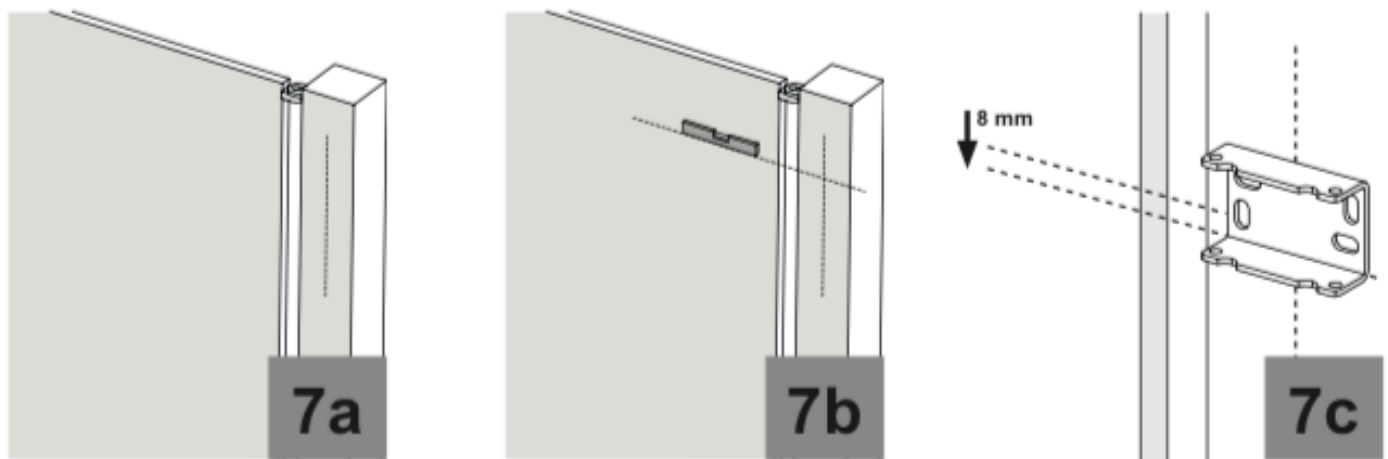

Fig. 8 EN - Fixing the motor
 DE - Befestigung des Antriebs
 IT - Fissaggio motoriduttore
 FR - Fixation moteur

ES - Fijación del motorreductor
 PT - Fixação do motorreductor
 PL - Mocowanie motoreduktora

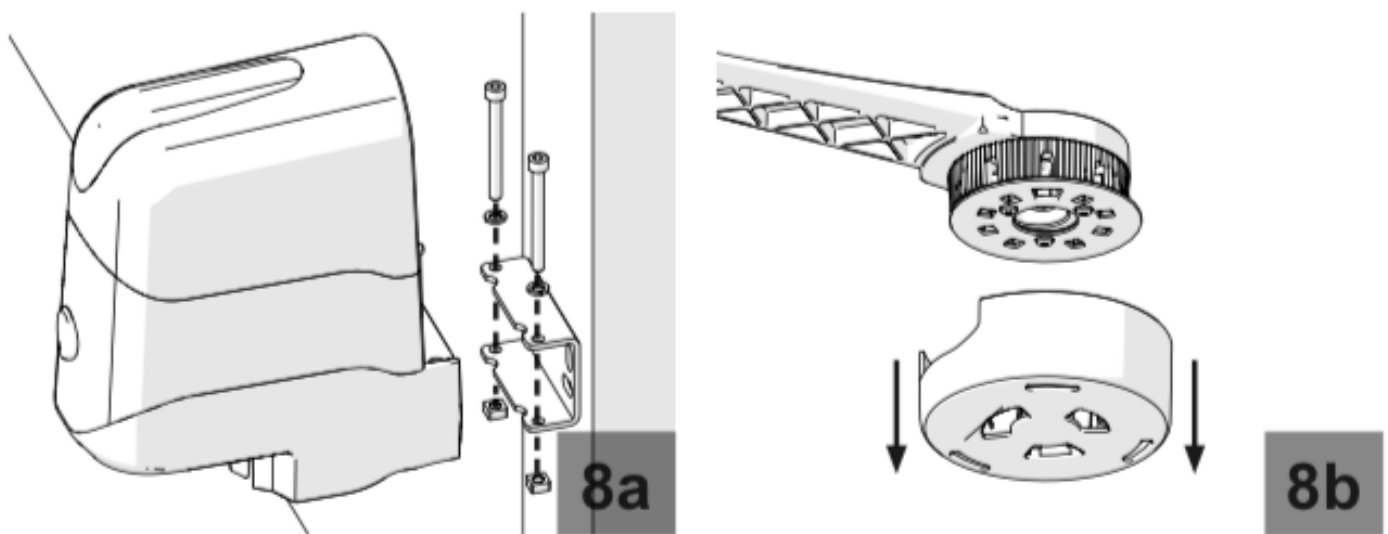

Fig. 9 EN - Fixing the leaf bracket
 DE - Befestigung des Torbeschlags
 IT - Fissaggio staffe
 FR - Fixation patte portail

ES - Fijación del estribo en la puerta
 PT - Fixação da placa do portão
 PL - Mocowanie obejmy bramy

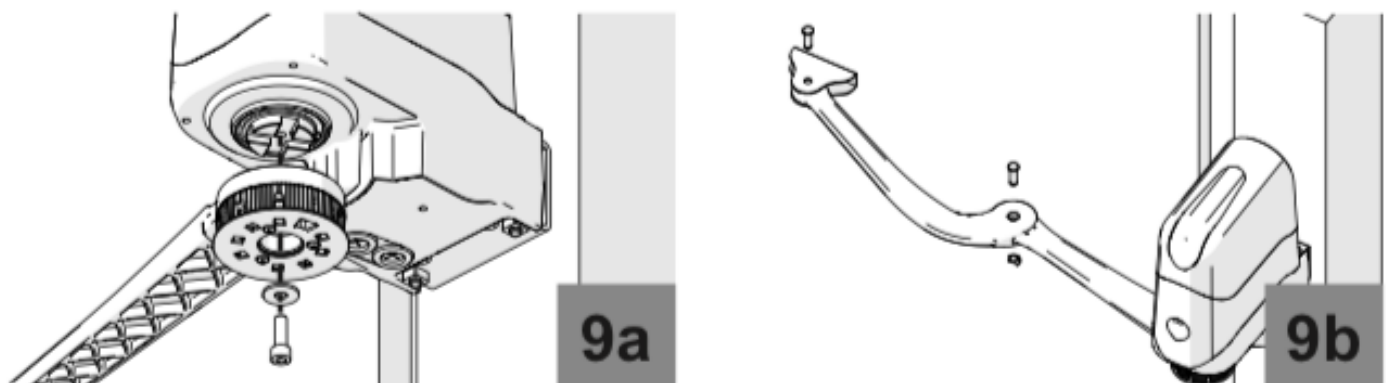

Fig. 10 EN - Gearmotor release
 DE - Entriegeln des Getriebemotors
 IT - Sblocco del motoriduttore
 FR - Déblocage du motoréducteur

ES - Desbloqueo del motorreductor
 PT - Desbloqueio do motorreductor
 PL - Odblokowanie motoreduktora

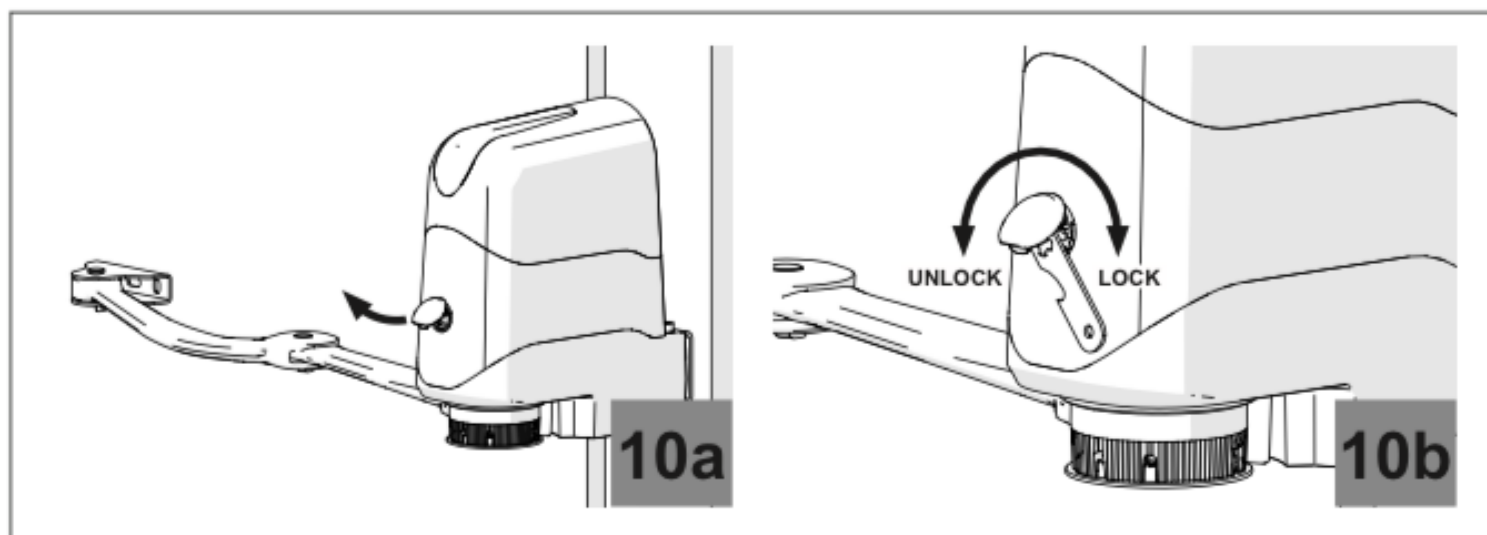

Fig. 11 EN - Fixing the leaf bracket
 DE - Anbringung des Torbeschlags
 IT - Fissaggio staffa cancello
 FR - Fixation patte portail

ES - Fijación del estribo en la puerta
 PT - Fixação da placa do portão
 PL - Mocowanie obejmy bramy

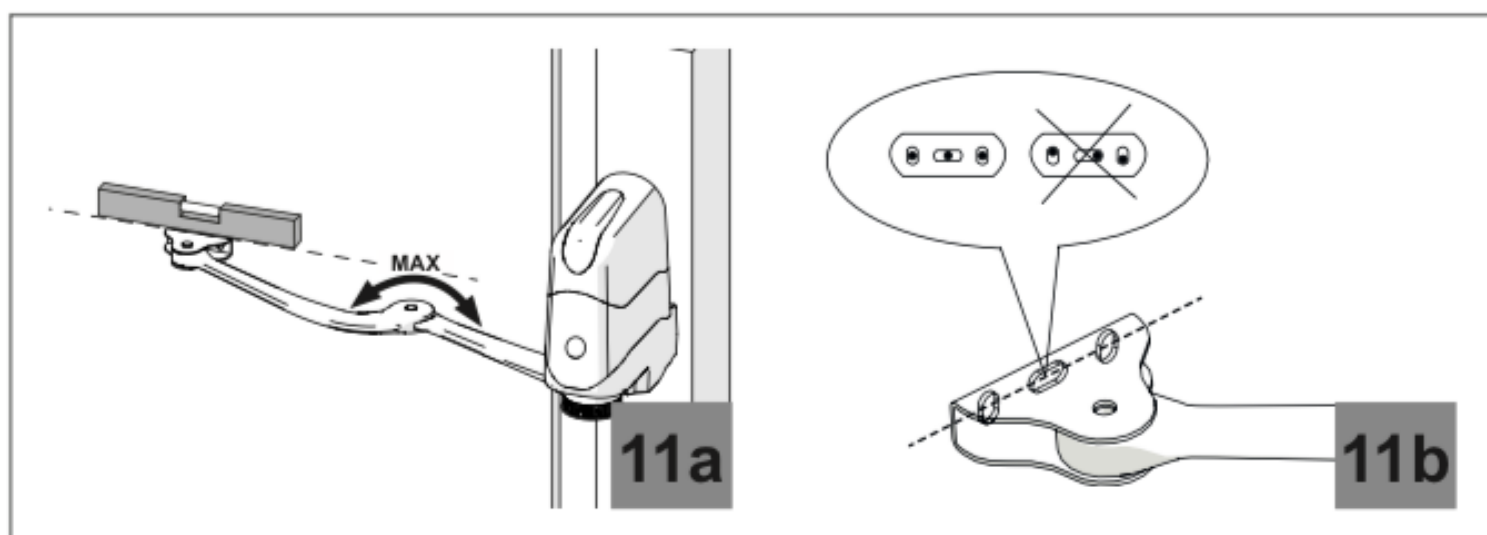

Fig. 12 EN - Mechanical stop adjustment
 DE - Einstellung der mechanischen Endanschläge
 IT - Regolazione dei finecorsa meccanici
 FR - Réglage bloc de fin de course mécaniques

ES - Regulación de los finales de carrera mecánicos
 PT - Regulação dos blocos dos fins de curso mecânicos
 PL - Regulacja mechanicznych wyłączników krańcowych

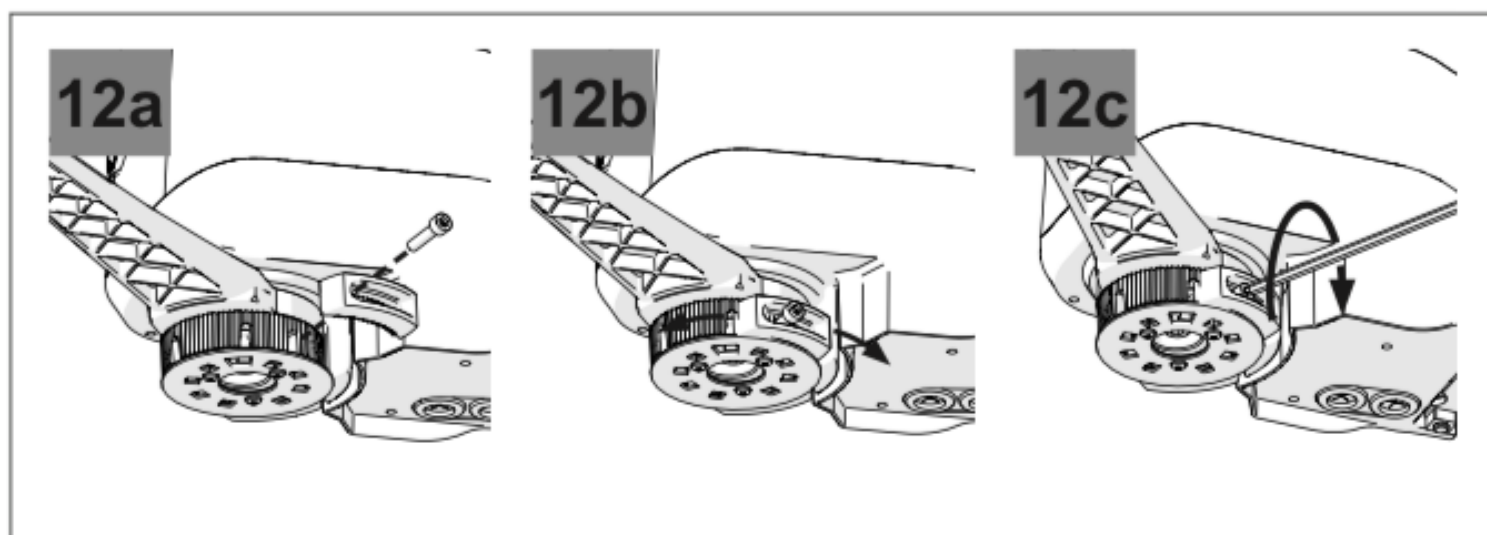

Fig. 13 EN - Limit switch cap assembly
 DE - Montage der Endschalterkappe
 IT - Montaggio tappo finecorsa
 FR - Montage bouchon fin de course

ES - Montaje tapón fin de recorrido
 PT - Montagem da tampa do fim de curso
 PL - Montaż zatyczki wyłącznika krańcowego

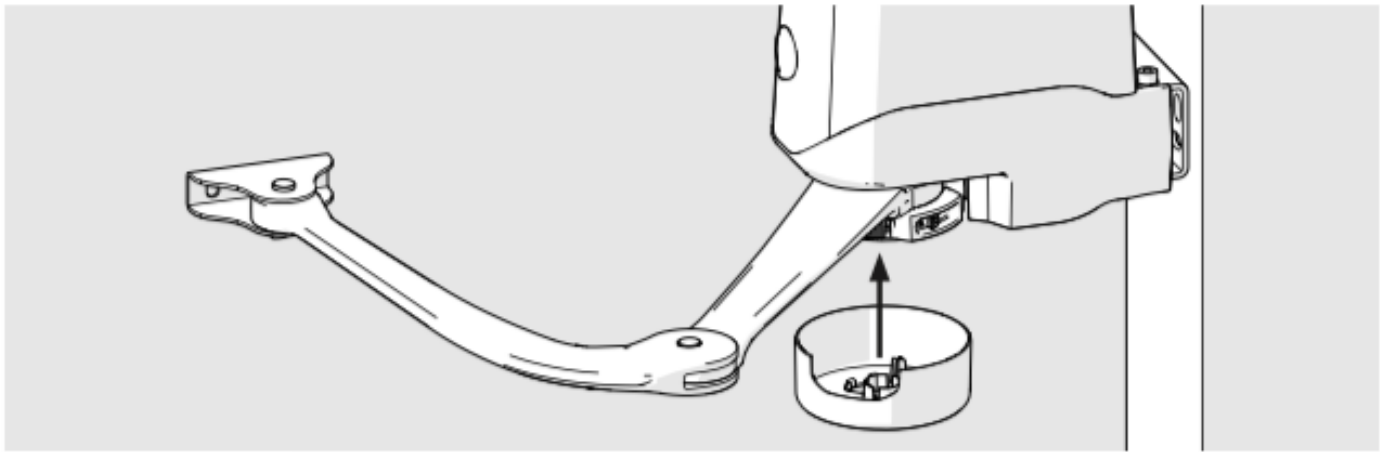
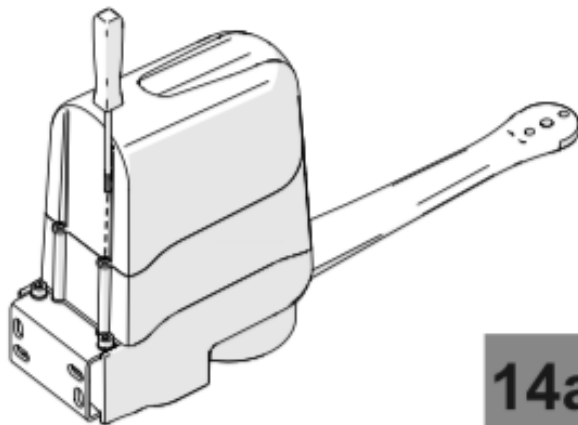
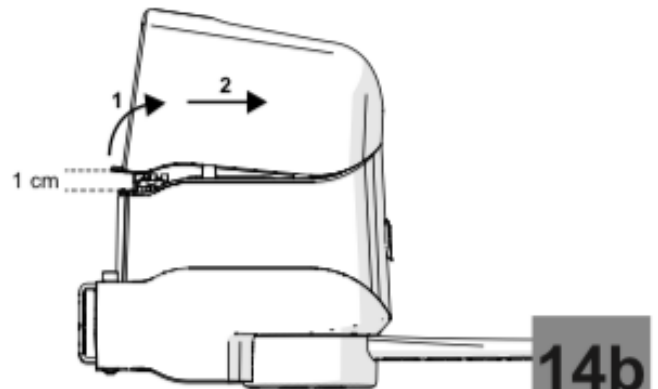

Fig. 14 EN - Electrical connections
 DE - Elektrische Anschlüsse
 IT - Connessioni elettriche
 FR - Connexions électriques

ES - Conexiones eléctricas
 PT - Conexões eléctricas
 PL - Połączenia elektryczne



14a



14b

Fig. 15 EN - Positioning the cover
 DE - Position des Deckels
 IT - Posizione coperchio
 FR - Position couvercle

ES - Posición de la cubierta
 PT - Posição da tampa
 PL - Położenie pokrywy

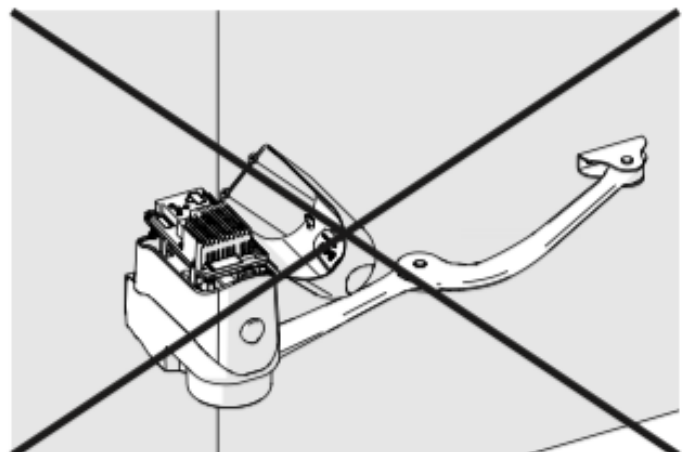
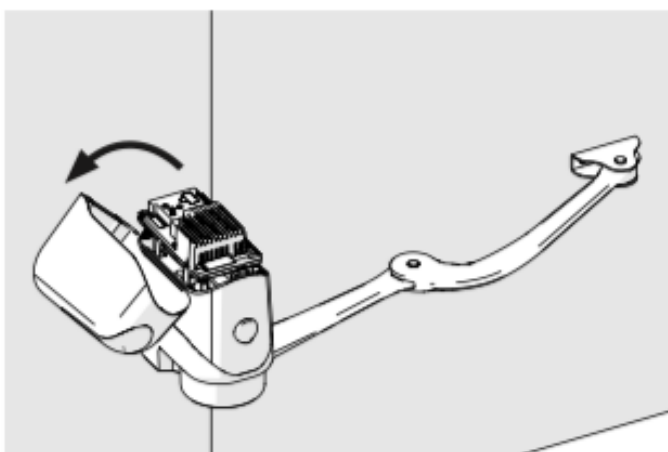

Fig. 16 EN - Connections and cables
 DE - Anschlüsse und Verdrahtung
 IT - Conessioni e cablaggi
 FR - Connexions et câblages

ES - Conexiones y cableados
 PT - Ligações e cabos
 PL - Podłączenia i okablowanie

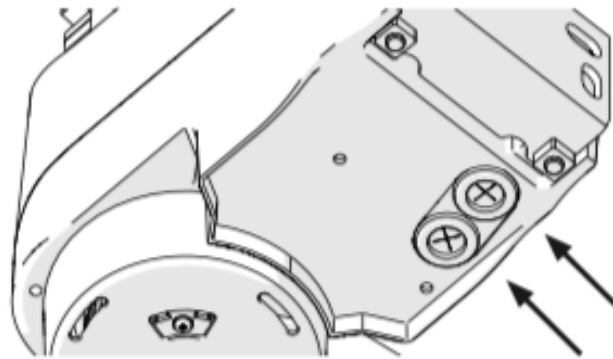

Fig. 17 EN - Connections and cables
 DE - Anschlüsse und Verdrahtung
 IT - Conessioni e cablaggi
 FR - Connexions et câblages

ES - Conexiones y cableados
 PT - Ligações e cabos
 PL - Podłączenia i okablowanie

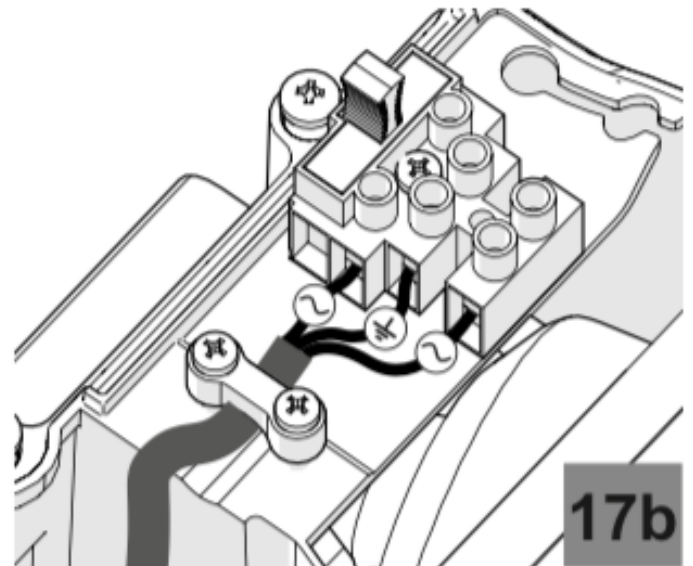
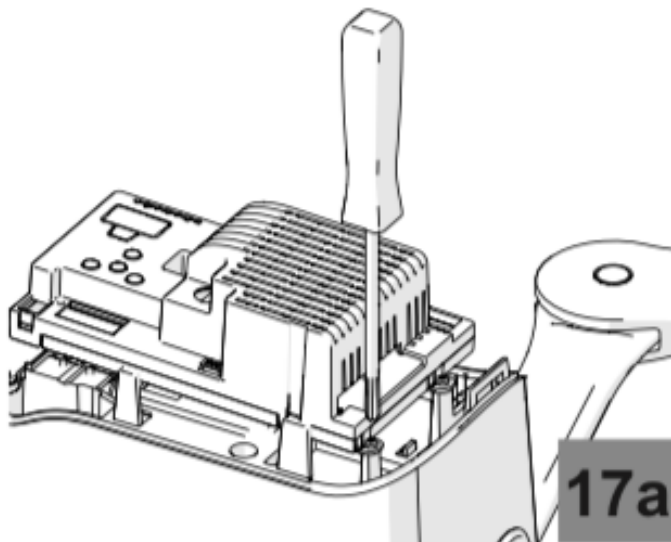

Fig. 18 EN - Second motor connections
 DE - Anschluss des Zweitmotors
 IT - Collegamento secondo motore
 FR - Connexion deuxième moteur

ES - Conexión del segundo motor
 PT - Ligação do segundo motor
 PL - Podłączenie drugiego silnika

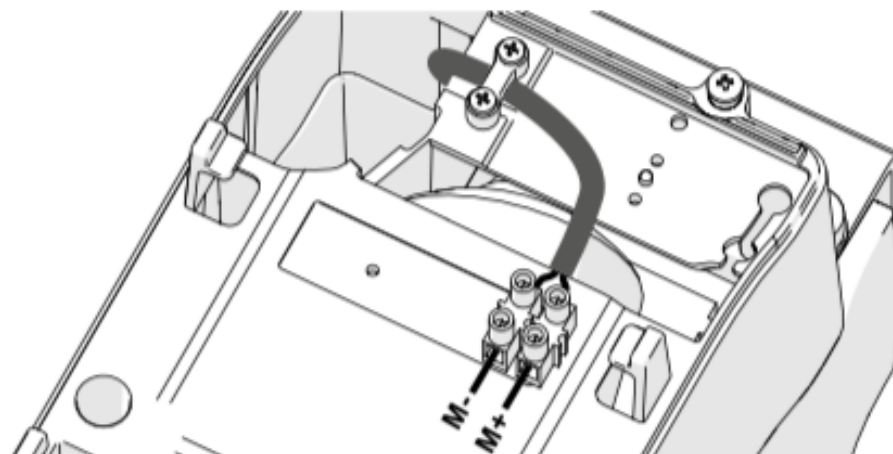

TABLE OF CONTENTS

Images p. 2

1 Safety warnings p. 10

2 Product overview p. 12

2.1 Product description p. 12

2.2 Models and characteristics p. 12

3 Preliminary checks p. 12

4 Installing the product p. 13

4.1 Installation p. 13

4.2 Adjusting the mechanical limit switch in
opening p. 13

4.3 Electrical connections p. 13

4.4 Mechanical and electronic connections of the
second motor p. 13

5 Testing and commissioning p. 14

5.1 Testing p. 14

5.2 Commissioning p. 14

6 EC Declaration of Conformity p. 51

ATTENTION !

ORIGINAL INSTRUCTIONS - important safety instructions. Follow the instructions since incorrect installation can lead to severe injury! Save these instructions.

Read the instructions carefully before proceeding with installation.

The design and manufacture of the devices making up the product and the information in this manual are compliant with current safety standards. However, incorrect installation or programming may cause serious injury to those working on or using the system. Compliance with the instructions provided here when installing the product is therefore extremely important.

If in any doubt regarding installation, do not proceed and contact the Marantec Technical Service for clarifications.

Under European legislation, an automatic door or gate system must comply with the standards envisaged in the Directive 2006/42/EC (Machinery Directive) and in particular standards; EN 12453; EN 12635 and EN 13241-1, which enable declaration of presumed conformity of the automation system.

Therefore, final connection of the automation system to the electrical mains, system testing, commissioning and routine maintenance must be performed by skilled, qualified personnel, in observance of the instructions in the "Testing and commissioning the automation system" section.

The aforesaid personnel are also responsible for the tests required to verify the solutions adopted according to the risks present, and for ensuring observance of all legal provisions, standards and regulations, with particular reference to all requirements of the EN 12453 standard which establishes the test methods for testing door and gate automation systems.

ATTENTION !

Before starting installation, perform the following checks and assessments:

ensure that every device used to set up the automation system is suited to the intended system overall. For this purpose, pay special attention to the data provided in the "Technical specifications" section. Do not proceed with installation if any one of these devices is not suitable for its intended purpose;

check that the devices purchased are sufficient to guarantee system safety and functionality;

perform a risk assessment, including a list of the essential safety requirements as envisaged in Annex I of the Machinery Directive, specifying the solutions adopted. The risk assessment is one of the documents included in the automation system's technical file. This must be compiled by a professional installer.

Considering the risk situations that may arise during installation phases and use of the product, the automation system must be installed in compliance with the following safety precautions:

never make modifications to any part of the automation system other than those specified in this manual. Operations of this type can only lead to malfunctions. The manufacturer declines all liability for damage caused by unauthorised modifications to products;

if the power cable is damaged, it must be replaced by the manufacturer or its after-sales service, or in all cases by a person with similar qualifications, to prevent all risks;

do not allow parts of the automation system to be immersed in water or other liquids. During installation ensure that no liquids are able to enter the various devices; should this occur, disconnect the power supply immediately and contact a Marantec Service Centre. Use of the automation system in these conditions may cause hazards;

never place automation system components near to sources of heat or expose them to naked lights. This may damage system components and cause malfunctions, fire or hazards;

 ATTENTION !

The drive shall be disconnected from its power source during cleaning, maintenance and when replacing parts. If the disconnect device is not in a visible location, affix a notice stating: "MAINTENANCE IN PROGRESS":

connect all devices to an electric power line equipped with an earthing system;

the product cannot be considered to provide effective protection against intrusion. If effective protection is required, the automation system must be combined with other devices;

the product may not be used until the automation system "commissioning" procedure has been performed as specified in the "Automation system testing and commissioning" section;

the system power supply line must include a circuit breaker device with a contact gap allowing complete disconnection in the conditions specified by class III overvoltage;

use unions with IP55 or higher protection when connecting hoses, pipes or cable glands;

the electrical system upstream of the automation system must comply with the relevant regulations and be constructed to good workmanship standards;

this appliance can be used by children aged from 8 years and above and persons with reduced physical, sensory or mental capabilities or lack of experience and knowledge if they have been given supervision or instruction concerning use of the appliance in a safe way and understand the hazards involved;

before starting the automation system, ensure that there is no-one in the immediate vicinity;

before proceeding with any cleaning or maintenance work on the automation system, disconnect it from the electrical mains;

special care must be taken to avoid crushing between the part operated by the automation system and any fixed parts around it;

children must be supervised to ensure that they do not play with the equipment;

install any fixed control at a height of at least 1,5m and within sight of the door but away from moving parts;

after installation, ensure that parts of the door do not extend over public footpaths or roads;

when the appliance is provided with a separate stop button, that stop button shall be unambiguously identifiable;

install the automation exclusively on gates operating on flat surfaces, that is, they are not installed on an up or down tilt;

install exclusively on gates that are sturdy enough and suitable to withstand the loads generated by the automation itself;

do not subject the automation to direct jets of water, such as sprinklers or pressure washers;

if the automation system exceeds 20 kg in weight, it must be handled using safety lifting devices (IEC 60335-2-103: 2015);

provide appropriate safety protections in order to avoid crushing and becoming trapped between the moving guided part and any surrounding fixed elements;

make sure that any protection or safety devices, in addition to the manual release, work correctly;

place the automation identification plate at a clearly visible point;

keep the manuals and technical files of all the devices used to create the automation;

at the end of the automation installation it is advisable to hand over the manuals relating to the warnings intended for the end user;

ATTENTION !

Frequently examine the installation for imbalance where applicable and signs of wear or damage to cables, springs and mounting. Do not use if repair or adjustment is necessary.

ATTENTION !

The automation system component packaging material must be disposed of in full observance of current local waste disposal legislation.

Marantec Antriebs- und Steuerungstechnik GmbH & Co. KG reserves the right to amend these instructions if necessary; they and/or any more recent versions are available at www.marantec.com.

2 - PRODUCT OVERVIEW

2.1 - Description of the product

The COMFORT REP gear motors are destined to be installed in systems for the automation of gates with hinged doors.

The COMFORT REP gear motors have been designed and constructed to be fitted onto hinged doors within the weight limits

indicated in the technical specifications table.

The use of gear motors for applications which differ from those indicated above is prohibited.

2.2 - Model and technical characteristics

CODE	DESCRIPTION
REP2224	24 Vdc gear motor for hinged doors with max length 2,3 m or weight 250 Kg, 230 Vac
REP2224S	24 Vdc gear motor for hinged doors with max length 2,3 m or weight 250 Kg, 230 Vac, without control unit

TECHNICAL DATA			
MODELS		REP2224	REP2224S
TECHNICAL SPECIFICATIONS			
Torque	Nm	120	120
Working cycle	cycles/hour	60	60
Opening time at 90°	sec	14-20	14-20
Control board		CBX20224	-
Power supply	Vac	230	-
Power supply	Vdc	-	24
Absorption	A	0,6	2
Engine power	W	115	50
Integrated lights		-	-
Degree of protection	IP	44	44
Dimensions (L - P - H)	mm	125 - 260 - 310	125 - 260 - 310
Weight	Kg	10,5	8
Operating temperature	°C	-20°+55°	-20°+55°
Leaves maximum weight	Kg	250	250

3 - PRELIMINARY CHECKS

Before installing this product, verify and check the following steps:

- Check that the gate or door are suitable for automation
- The weight and size of the gate or door must be within the maximum permissible operating limits specified in Fig. 2
- Check the presence and strength of the security mechanical stops of the gate or door
- Check that the mounting area of the product is not subject to flooding
- Conditions of high acidity or salinity or proximity to heat sources could cause malfunction of the product
- Extreme weather conditions (for example the presence of snow, ice, high temperature range, high temperatures) may increase the friction and therefore the force required for the handling and initial starting point may be higher than under normal conditions.
- Check that the manual operation of gate or door is smooth and friction-free and there is no risk of derailment of the same

- Check that the gate or door are in equilibrium and stationary if left in any position
- Check that the power line to supply the product is equipped with proper grounding safety and protected by a magnetothermal and differential security device
- Provide the power system with a disconnecting device with a gap of contacts enabling full disconnection under the conditions dictated by the overvoltage category III.
- Ensure that all materials used for the installation comply with current regulations

4 - PRODUCT INSTALLATION

4.1 - Installation

Before starting the installation, make sure that the product is intact and that the packaging contains all the components shown in Fig.3.

Make sure that the mounting area is compatible with the overall dimensions (Fig.1).

Check the allowed opening angle according to the fixing points of the brackets in Fig.4 and in the diagram in Fig.5.

Fig.6 is an example of a typical system:

- Photocells (1)
- Operators (2)
- Posts for photocells (3)
- Key or digital switch (4)
- Flashing light with integrated aerial (5)

Mounting

Measure the value C (Fig. 4) = distance between the rotation fulcrum of the leaf and the pillar surface where the rear bracket will be fixed.

Move manually the leaf up to the opening required (maximum 120°); establish the value of the maximum opening angle of each leaf.

Mark on the diagram in Fig.5 the value C and trace an horizontal line up to intersect the area that includes the angle value measured before.

Trace some vertical lines on the intersection points between the horizontal line and the area in order to find the useful values for the dimension A (fig. 4). Chose the value A in this range. Mark on the pillar the value A and trace a vertical line in correspondence (Fig.7a).

Mounting the motor bracket to the pillar

Draw a horizontal line on the column at the same height as the gate door fixing bracket will be (Fig. 7b). Position the wall fixing bracket so that the inside of the lower edge is 8mm lower than the horizontal line in Fig. 7b and secure it using suitable screws

and washers (not supplied). Fasten the gearmotor to the column bracket with the supplied screws, washers and nuts (Fig. 8a).

ATTENTION !

An off-axis mounting can cause malfunctioning and damage the automation system.

Motor arm fixing (straight arm)

Release the limit switch cover from the straight arm by pulling it (Fig. 8b). Connect the arm to the gearmotor, aligning the corresponding cross profiles. Join the two elements with the M8x25TCE screw and washer supplied, tightening firmly (Fig. 9a). Secure the curved arm to the straight arm using the pin and the stop ring (Fig. 9b). Secure the door fixing bracket to the curved arm using the pin but without the stop ring (Fig. 9b)

Gate bracket fixing

Bring the gate door to the maximum closing position. Release the gearmotor (Fig. 10a and Fig. 10b)

Fully extend the arms, bring the curved arm closer to the door and place the door fixing bracket on the latter. Holding the bracket in contact with the door with one hand, try to open and close completely (Fig. 11a).

Secure the gate bracket to the door with suitable screws (not supplied) (Fig. 11b) and fix the pin with the stop ring.

ATTENTION !

An off-axis mounting can cause malfunctioning and damage the automation system.

4.2 - Adjusting the mechanical limit switch

With the gearmotor released, open the leaf of the gate to the desired opening point. Take the limit switch block, place it on the arm in the crown gear making sure that the limit switch teeth are perfectly engaged with the crown gear and that the locking is stable, then fix it with the M6x25TCE screw in one of the locking holes (Fig. 12a). It is possible to adjust with precision the opening position of the leaf by loosening the limit switch screw and moving the block to the positions permitted by the teeth of the crown gear (Fig. 12b). If an intermediate position between two teeth is

required, simply rotate the limit switch block by 180° with respect to the fixing screw. Once the adjustment is complete, tighten the screw (Fig. 12c). Close the leaf of the gate to the desired closing point and use the same procedure to adjust the closing limit switch using the second block. Once the adjustment of both limit switches has been completed, reposition the cover on the arm, applying light pressure until it clicks and the protective cover remains fixed to the arm in a stable position (Fig. 13).

4.3 - Electrical connections

Unscrew the cover screws (Fig.14a). Raise the back by about 1 cm then slide it out forwards (Fig.14b).

ATTENTION !

The lights on the cover are connected by two wires, disconnect the terminal or lay carefully the cover upside-down on the external part (Fig.15).

Insert the power cable (Fig. 16). Loosen the screws of the control unit support (Fig. 17a). Connect the wires of the power supply cable to the terminal block according to the wiring diagram (Fig. 17b). Proceed with the other connections following the instructions of the control unit on the motor and at the end fasten the control unit to the support again. Replace the upper cover and tighten the 2 screws that secure the cover.

4.4 - Mechanical and electronic connections of the second motor

In case of installation of the second motor, follow the above mentioned instructions for the mechanical mounting, for the electrical connections refer to the Fig. 18.

5 - TESTING AND COMMISSION THE AUTOMATION

The system must be tested by a qualified technician, who must perform the tests required by the relevant standards in relation to the risks present and must check that the installation complies with

the relevant regulatory requirements, especially with the EN12453 standard which specifies the test methods for gate and door automation systems.

5.1 - Testing

All the system components must be tested following the procedures described in their respective operator manuals;

ensure that the recommendations in Chapter 1 – Safety Warnings - have been complied with;

check that the door can move freely once the automation is released and that it is in balance and therefore remains stationary if left in any position;

check that all the connected devices (photocells, sensitive edges, emergency buttons, etc.) are operating correctly by performing door opening, closing and stop tests using the connected control devices (transmitters, buttons or switches);

perform the impact measurements as required by the EN12453 standard, adjusting the control unit's speed, motor force and deceleration functions if the measurements do not give the required results, until the correct setting is obtained.

5.2 - Commissioning

Once all (and not just some) of the system devices have passed the testing procedure, the system can be commissioned;

the system's technical dossier must be produced and kept for 10 years. It must contain the electrical wiring diagram, a drawing or photograph of the system, the analysis of the risks and the solutions adopted to deal with them, the manufacturer's declaration of conformity for all connected devices, the operator's manual for every device and the system maintenance plan;

fix a plate on the door indicating the automation data, the name of the person responsible for commissioning, the serial number, the year of construction and the CE mark;

also fit a plate specifying the procedure for releasing the system by hand;

draw up the declaration of conformity, the instructions and precautions for use for the end user and the system maintenance plan and consign them to the end user;

ensure that the user has fully understood how to operate the system in automatic, manual and emergency modes;

the end user must also be informed in writing about any risks and hazards still present;

ATTENTION !

After detection of an obstacle, the door stops on opening and automatic closing is excluded; to resume movement, press the control button or use the transmitter.

 AC Casablanca, 867 AV 2 MARS ETG RC
HADDAOIA 3, Casablanca 20470



 polyopenmaroc@gmail.com

+ 212 522502539  + 212 666453856 